

Dow University of Health Sciences



Bidding Documents

Single Stage – One Envelope Procedure
As per Rule 46 (1) of SPPR, 2010

IFB / NIT No: DUHS/DP/2026/343/344 Dated 13 May 2026

**PROCUREMENT OF FURNITURE/ FIXTURES
FOR CONSTRUCTION OF SEMINAR HALL
(NIT. Ref. No. DUSH/DP/2026/344)**

TABLE OF CONTENTS

Part One - Section I Instructions to Bidders.....	5
Instructions to Bidders	6
A. Introduction	6
1. Source of Funds	6
2. Eligible Bidders	6
3. Eligible Goods and Services	6
4. Cost of Bidding.....	7
B. The Bidding Documents.....	7
5. Content of Bidding Documents	7
6. Clarification of Bidding Documents	7
7. Amendment of Bidding Documents	7
C. Preparation of Bids.....	8
8. Language of Bid	8
9. Documents Comprising the Bid.....	8
10. Bid Form	8
11. Bid Prices.....	8
12. Bid Currencies	8
13. Documents Establishing Bidder’s Eligibility and Qualification	9
14. Documents Establishing Goods’ Eligibility and Conformity to Bidding Documents	9
15. Bid Security.....	10
16. Period of Validity of Bids.....	10
17. Format and Signing of Bid.....	10
D. Submission of Bids.....	11
18. Sealing and Marking of Bids.....	11
19. Deadline for Submission of Bids	11
20. Late Bids.....	11
21. Modification and Withdrawal of Bids.....	11
E. Opening and Evaluation of Bids	12
22. Opening of Bids by the Procuring agency	12
23. Clarification of Bids	12
24. Preliminary Examination	12
25. Evaluation and Comparison of Bids	13
26. Contacting the Procuring agency	14
F. Award of Contract.....	14
27. Post-qualification	14
28. Award Criteria	14
29. Procuring agency’s Right to Vary Quantities at Time of Award	14
30. Procuring agency’s Right to Accept any Bid and to Reject any or All Bids	15
31. Notification of Award	15
32. Signing of Contract	15
33. Performance Security	15
34. Corrupt or Fraudulent Practices	15
35. Integrity Pact	16
Part One - Section II General Conditions of Contract.....	17
General Conditions of Contract	18
1. Definitions	18
2. Application	18
3. Country of Origin	18
4. Technical Specifications	19
5. Use of Contract Documents and Information; Inspection and Audit by the Government.....	19
6. Patent Rights.....	19

7.	Performance Security	19
8.	Inspections and Tests	20
9.	Packing.....	20
10.	Delivery and Documents.....	20
11.	Insurance.....	20
12.	Transportation.....	21
13.	Incidental Services	21
14.	Warranty	21
15.	Payment	22
16.	Prices	22
17.	Change Orders	22
18.	Contract Amendments	23
19.	Assignment.....	23
20.	Subcontracts	23
21.	Delay in the Supplier’s Performance	23
22.	Liquidated Damages.....	23
23.	Termination for Default	23
24.	Force Majeure	24
25.	Termination for Insolvency	24
26.	Termination for Convenience.....	24
27.	Resolution of disputes	25
28.	Governing Language	25
29.	Applicable Law.....	25
30.	Notices.....	25
31.	Taxes and Duties	25
Part Two (Procurement Specific Provisions).....		26
Part Two - Section I Invitation for Bids.....		27
Part Two - Section II Bid Data Sheet.....		29
Part Two - Section III Special Conditions of Contract		35
Special Conditions of Contract		36
1.	Definitions (GCC Clause 1)	36
2.	Country of Origin (GCC Clause 3).....	36
3.	Technical Specifications (GCC Clause 4).....	36
4.	Performance Security (GCC Clause 7)	36
5.	Packing (GCC Clause 9)	36
6.	Delivery and Documents (GCC Clause 10).....	36
7.	Insurance (GCC Clause 11).....	37
8.	Warranty (GCC Clause 14).....	37
9.	Payment (GCC Clause 15).....	37
10.	Prices (GCC Clause 16).....	37
11.	Liquidated Damages (GCC Clause 22)	37
12.	Resolution of Disputes (GCC Clause 27)	37
13.	Governing Language (GCC Clause 28)	38
14.	Applicable Law (GCC Clause 29)	38
15.	Notices (GCC Clause 30)	38
Part Two - Section IV Schedule of Requirements		39
Part Two - Section V Technical Specifications		41
Part Two - Section VI Sample Forms		57
A. Bid Form and Price Schedules.....		58
B. Bid Security Form.....		60
C. Contract Form		61
D. Performance Security Form		62

E. Bank Guarantee for Advance Payment	63
F. Manufacturer’s Authorization Form.....	64
G. Integrity Pact (AFFIDAVIT)	65
<i>Sample Forms.....</i>	66

**Part One - Section I
Instructions to Bidders**

Instructions to Bidders

A. Introduction

1. Source of Funds

- 1.1 The Procuring agency has allocated funds / received / applied for loan / grant / federal / provincial / local government funds from the source(s) indicated in the bidding data in various currencies towards the cost of the project / schemes specified in the bidding data and it is intended that part of the proceeds of this loan / grant / funds / will be applied to eligible payments under the contract for which these bidding documents are issued.
- 1.2 Payment by the Fund will be made by procuring agency from university funds or only at the request of the Procuring agency and upon approval by the Government of Sindh., and in case of a project will be subject in all respect to the terms and conditions of the agreement. The Project Agreement prohibits a withdrawal from the allocated fund account for the purpose of any payment to persons or entities, or for any import of goods, if such payment or import, to the knowledge of the Federal Government / Sindh Government, is prohibited by a decision of the United Nations Security Council taken under Chapter VII of the Charter of the United Nations. No party other than the Procuring agency shall derive any rights from the Project Agreement or have any claim to the allocated fund proceeds.

2. Eligible Bidders

- 2.1 This Invitation for Bids is open to all suppliers from eligible sources as defined in the SPP Rules, 2010 (Amended) and its Bidding Documents except as provided hereinafter.
- 2.2 Bidders should not be associated, or have been associated in the past, directly or indirectly, with a firm or any of its affiliates which have been engaged by the Procuring agency to provide consulting services for the preparation of the design, specifications, and other documents to be used for the procurement of the goods to be purchased under this Invitation for Bids.
- 2.3 Government-owned enterprises in the Province of Sindh may participate only if they are legally and financially autonomous, if they operate under commercial law, and if they are not a dependent agency of the Government of Sindh.
- 2.4 Bidders intend to enter into an agreement or under an existing agreement in the form of a Joint Venture (JV) or Consortium shall not be eligible, unless otherwise specified in the Bid Data Sheet.
- 2.5 Bidders shall not be eligible to bid if they are under a declaration of ineligibility for corrupt and fraudulent practices issued by any government organization in accordance with sub-clause 34.1.
- 2.6 The bidder must be registered with E-Pak Acquisition and Disposal Systems (EPADS) of Sindh Public Procurement Regulatory Authority (SPPRA).

3. Eligible Goods and Services

- 3.1 All goods and related services to be supplied under the contract shall have their origin in eligible source countries, defined in the SPP Rules, 2010 (Amended) and its Bidding Documents, and all expenditures made under the contract will be limited to such goods and services.
- 3.2 For purposes of this clause, "origin" means the place where the goods are mined, grown, or produced, or the place from which the related services are supplied. Goods are produced when, through manufacturing, processing, or substantial and major assembly of components, a commercially recognized product results that is

substantially different in basic characteristics or in purpose or utility from its components.

3.3 The origin of goods and services is distinct from the nationality of the Bidder

4. Cost of Bidding

4.1 The Bidder shall bear all costs associated with the preparation and submission of its bid, and the Procuring agency named in the Bid Data Sheet, hereinafter referred to as “the Procuring agency,” will in no case be responsible or liable for those costs, regardless of the conduct or outcome of the bidding process.

B. The Bidding Documents

5. Content of Bidding Documents

5.1 the bidding documents include:

- a. Instructions to Bidders (ITB)
- b. Bid Data Sheet
- c. General Conditions of Contract (GCC)
- d. Special Conditions of Contract (SCC)
- e. Schedule of Requirements
- f. Technical Specifications
- g. Bid Form and Price Schedules
- h. Bid Security Form
- i. Contract Form
- j. Performance Security Form
- k. Manufacturer’s Authorization Form

5.2 The Bidder is expected to examine all instructions, forms, terms, and specifications in the bidding documents. Failure to furnish all information required by the bidding documents or to submit a bid not substantially responsive to the bidding documents in every respect will be at the Bidder’s risk and may result in the rejection of its bid.

6. Clarification of Bidding Documents

6.1 An interested Bidder requiring any clarification of the bidding documents may notify the Procuring agency in writing. The Procuring agency will respond in writing to any request for clarification of the bidding documents which it receives no later than five working days prior to the deadline for the submission of bids prescribed in the Bid Data Sheet. Written copies of the Procuring agency’s response (including an explanation of the query but without identifying the source of inquiry) will be sent to all interested bidders that have received the bidding documents.

7. Amendment of Bidding Documents

7.1 At any time prior to the deadline for submission of bids, the Procuring agency, for any reason, whether at its own initiative or in response to a clarification requested by a interested Bidder, may modify the bidding documents by amendment.

7.2 All interested bidders that have received the bidding documents will be notified of the amendment in writing, and will be binding on them.

7.3 In order to allow interested bidders reasonable time in which to take the amendment into account in preparing their bids, the Procuring agency, at its discretion, may extend the deadline for the submission of bids.

C. Preparation of Bids

8. Language of Bid

- 8.1 The bid prepared by the Bidder, as well as all correspondence and documents relating to the bid exchanged by the Bidder and the Procuring agency shall be written in the language specified in the Bid Data Sheet. Supporting documents and printed literature furnished by the Bidder may be in another language provided they are accompanied by an accurate translation of the relevant passages in the language specified in the Bid Data Sheet, in which case, for purposes of interpretation of the Bid, the translation shall govern.

9. Documents Comprising the Bid

- 9.1 The bid prepared by the Bidder shall comprise the following components:
- a. a Bid Form and a Price Schedule completed in accordance with ITB Clauses 10, 11, and 12;
 - b. documentary evidence established in accordance with ITB Clause 13 that the Bidder is eligible to bid and is qualified to perform the contract if its bid is accepted;
 - c. documentary evidence established in accordance with ITB Clause 14 that the goods and ancillary services to be supplied by the Bidder are eligible goods and services and conform to the bidding documents; and
 - d. bid security furnished in accordance with ITB Clause 15.

10. Bid Form

- 10.1 The Bidder shall complete the Bid Form and the appropriate Price Schedule furnished in the bidding documents, indicating the goods to be supplied, a brief description of the goods, their country of origin, quantity, and prices.

11. Bid Prices

- 11.1 The Bidder shall indicate on the appropriate Price Schedule the unit prices (where applicable) and total bid price of the goods it proposes to supply under the contract.
- 11.2 Prices indicated on the relevant Price Schedule shall be on delivered duty paid (DDP) basis. The price of other (incidental) services, if any, listed in the Bid Data Sheet will be entered separately.
- 11.3 The Bidder's separation of price components in accordance with ITB Clause 11.2 above will be solely for the purpose of facilitating the comparison of bids by the Procuring agency and will not in any way limit the Procuring agency's right to contract on any of the terms offered.
- 11.4 Prices quoted by the Bidder shall be fixed during the Bidder's performance of the contract and not subject to variation on any account, unless otherwise specified in the Bid Data Sheet. A bid submitted with an adjustable price quotation will be treated as nonresponsive and will be rejected, pursuant to ITB Clause 24. If, however, in accordance with the Bid Data Sheet, prices quoted by the Bidder shall be subject to adjustment during the performance of the contract, a bid submitted with a fixed price quotation will not be rejected, but the price adjustment would be treated as zero.

12. Bid Currencies

- 12.1 Prices shall be quoted in Pak Rupees unless otherwise specified in the Bid Data Sheet.

13. Documents Establishing Bidder's Eligibility and Qualification

- 13.1 Pursuant to ITB Clause 9, the Bidder shall furnish, as part of its bid, documents establishing the Bidder's eligibility to bid and its qualifications to perform the contract if its bid is accepted.
- 13.2 The documentary evidence of the Bidder's eligibility to bid shall establish to the Procuring agency's satisfaction that the Bidder, at the time of submission of its bid, is from an eligible country as defined under ITB Clause 2.
- 13.3 The documentary evidence of the Bidder's qualifications to perform the contract if its bid is accepted shall establish to the Procuring agency's satisfaction:
 - a. that, in the case of a Bidder offering to supply goods under the contract which the Bidder did not manufacture or otherwise produce, the Bidder has been duly authorized by the goods' Manufacturer or producer to supply the goods in the Procuring agency's country;
 - b. that the Bidder has the financial, technical, and production capability necessary to perform the contract;
 - c. that, in the case of a Bidder not doing business within the Procuring agency's country, the Bidder is or will be (if awarded the contract) represented by an Agent in that country equipped, and able to carry out the Supplier's maintenance, repair, and spare parts-stocking obligations prescribed in the Conditions of Contract and/or Technical Specifications; and
 - d. that the Bidder meets the qualification criteria listed in the Bid Data Sheet.

14. Documents Establishing Goods' Eligibility and Conformity to Bidding Documents

- 14.1 Pursuant to ITB Clause 9, the Bidder shall furnish, as part of its bid, documents establishing eligibility and conformity to the bidding documents of all goods and services which the Bidder proposes to supply under the contract.
- 14.2 The documentary evidence of the eligibility of the goods and services shall consist of a statement in the Price Schedule of the country of origin of the goods and services offered which shall be confirmed by a certificate of origin issued at the time of shipment.
- 14.3 The documentary evidence of conformity of the goods and services to the bidding documents may be in the form of literature, drawings, and data, and shall consist of:
 - a. a detailed description of the essential technical and performance characteristics of the goods;
 - b. a list giving full particulars, including available sources and current prices of spare parts, special tools, etc., necessary for the proper and continuing functioning of the goods for a period to be specified in the Bid Data Sheet, following commencement of the use of the goods by the Procuring agency; and
 - c. an item-by-item commentary on the Procuring agency's Technical Specifications demonstrating substantial responsiveness of the goods and services to those specifications, or a statement of deviations and exceptions to the provisions of the Technical Specifications.
- 14.4 For purposes of the commentary to be furnished pursuant to ITB Clause 14.3(c) above, the Bidder shall note that standards for workmanship, material, and equipment, as well as references to brand names or catalogue numbers designated by the Procuring agency in its Technical Specifications, are intended to be descriptive only and not restrictive. The Bidder may substitute alternative standards, brand names, and/or catalogue numbers in its bid, provided that it demonstrates to the Procuring agency's satisfaction that the substitutions ensure substantial equivalence to those designated in the Technical Specifications.

15. Bid Security

- 15.1 Pursuant to ITB Clause 9, the Bidder shall furnish, as part of its bid, a bid security in the amount specified in the Bid Data Sheet.
- 15.2 The bid security is required to protect the Procuring agency against the risk of Bidder's conduct which would warrant the security's forfeiture, pursuant to ITB Clause 15.7.
- 15.3 The bid security shall be in Pak. Rupees and shall be in one of the following forms:
- a. a bank guarantee or an irrevocable letter of credit issued by a reputable bank located in the Procuring agency's country, in the form provided in the bidding documents or another form acceptable to the Procuring agency and valid for thirty (30) days beyond the validity of the bid; or
 - b. irrevocable encashable on-demand Bank call-deposit.
- 15.4 Any bid not secured in accordance with ITB Clauses 15.1 and 15.3 will be rejected by the Procuring agency as nonresponsive, pursuant to ITB Clause 24.
- 15.5 Unsuccessful bidders' bid security will be discharged or returned as promptly as possible but not later than thirty (30) days after the expiration of the period of bid validity prescribed by the Procuring agency pursuant to ITB Clause 16.
- 15.6 The successful Bidder's bid security will be discharged upon the Bidder signing the contract, pursuant to ITB Clause 32, and furnishing the performance security, pursuant to ITB Clause 33.
- 15.7 The bid security may be forfeited:
- a. if a Bidder withdraws its bid during the period of bid validity specified by the Bidder on the Bid Form; or
 - b. in the case of a successful Bidder, if the Bidder fails:
 - i. to sign the contract in accordance with ITB Clause 32; **or**
 - ii. to furnish performance security in accordance with ITB Clause 33.

16. Period of Validity of Bids

- 16.1 Bids shall remain valid for the period specified in the Bid Data Sheet after the date of bid opening prescribed by the Procuring agency, pursuant to ITB Clause 19. A bid valid for a shorter period shall be rejected by the Procuring agency as nonresponsive.
- 16.2 In exceptional circumstances, the Procuring agency may solicit the Bidder's consent to an extension of the period of validity. The request and the responses thereto shall be made in writing. The bid security provided under ITB Clause 15 shall also be suitably extended. A Bidder may refuse the request without forfeiting its bid security. A Bidder granting the request will not be required nor permitted to modify its bid, except as provided in the bidding document.

17. Format and Signing of Bid

- 17.1 The Bidder shall prepare an original and the number of copies of the bid indicated in the Bid Data Sheet, clearly marking each "ORIGINAL BID" and "COPY OF BID," as appropriate. In the event of any discrepancy between them, the original shall govern.
- 17.2 The original and the copy or copies of the bid shall be typed or written in indelible ink and shall be signed by the Bidder or a person or persons duly authorized to bind the Bidder to the contract. All pages of the bid, except for un-amended printed literature, shall be initialed by the person or persons signing the bid.
- 17.3 Any interlineations, erasures, or overwriting shall be valid only if they are initialed by the person or persons signing the bid.
- 17.4 The Bidder shall furnish information as described in the Form of Bid on commissions or gratuities, if any, paid or to be paid to agents relating to this Bid, and to contract execution if the Bidder is awarded the contract.

D. Submission of Bids

18. Sealing and Marking of Bids

- 18.1 The bid shall be typed and shall be signed by the Bidder, the person signing the bid shall initial all pages of the bid. The Bidder shall submit (upload) typed Bid in original scanned copy through SPPRA (EPADS) portal, which shall be signed by the Bidder to bind the Bidder to the contract. Any interlineations, erasures, or overwriting shall be valid only if they are initialed by the person signing the bid. All bidding documents are to be duly attested (signed and stamped) by the authorized person of the bidder.
- 18.2 In Procedures of Open Competitive Bidding – the Envelope means encrypted electronic file(s). The Bid shall be submitted through the electronic procurement system of SPPRA (EPADS) and uploaded with the Technical Proposal and Financial Proposal (encrypted files as specified in EPADS). The original bid security scanned copy must be uploaded on EPADS. The original bid security shall be submitted at the address mentioned in the NIT/IFB/Bidding Documents/BDS. Bids shall: be addressed to the Procuring Agency at the address given in the Bid Data Sheet; and bear the title of procurement Activity indicated in the Bid Data Sheet.

19. Deadline for Submission of Bids

- 19.1 Bids must be received by the Procuring agency through SPPRA (EPADS) portal not later than the time and date specified in the Bid Data Sheet.
- 19.2 The Procuring agency may, at its discretion, extend this deadline for the submission of bids by amending the bidding documents in accordance with ITB Clause 7, in which case all rights and obligations of the Procuring agency and bidders previously subject to the deadline will thereafter be subject to the deadline as extended.

20. Late Bids

- 20.1 Any bid received by the Procuring agency after the deadline for submission of bids prescribed by the Procuring agency pursuant to ITB Clause 19 will be rejected and returned unopened to the Bidder.

21. Modification and Withdrawal of Bids

- 21.1 The Bidder may modify or withdraw its bid after the bid's submission, provided that written notice of the modification, including substitution or withdrawal of the bids, is received by the Procuring agency prior to the deadline prescribed for submission of bids.
- 21.2 The Bidder's modification or withdrawal notice shall be prepared, sealed, marked, and dispatched in accordance with the provisions of ITB Clause 18. by a signed confirmation copy, postmarked not later than the deadline for submission of bids.
- 21.3 No bid may be modified after the deadline for submission of bids.
- 21.4 No bid may be withdrawn in the interval between the deadline for submission of bids and the expiration of the period of bid validity specified by the Bidder on the Bid Form. Withdrawal of a bid during this interval may result in the Bidder's forfeiture of its bid security, pursuant to the ITB Clause 15.7.

E. Opening and Evaluation of Bids

22. Opening of Bids by the Procuring agency

- 22.1 The Procuring agency will open all bids (electronically from SPPRA (EPADS) portal) in the presence of bidders' representatives who choose to attend, at the time, on the date, and at the place specified in the Bid Data Sheet. The bidders' representatives who are present shall sign a register evidencing their attendance.
- 22.2 The bidders' names, bid modifications or withdrawals, bid prices, discounts, and the presence or absence of requisite bid security and such other details as the Procuring agency, at its discretion, may consider appropriate, will be announced at the opening. No bid shall be rejected at bid opening, except for late bids, which shall be returned unopened to the Bidder pursuant to ITB Clause 20.
- 22.3 Bids (and modifications sent pursuant to ITB Clause 21.2) that are not opened electronically and read out at bid opening shall not be considered further for evaluation, irrespective of the circumstances, including but not limited to bugs, viruses, system glitches, not readable file etc. Withdrawn bids will not be opened.
- 22.4 The Procuring agency will prepare minutes of the bid opening.

23. Clarification of Bids

- 23.1 During evaluation of the bids, the Procuring agency may, at its discretion, ask the Bidder for a clarification of its bid. The request for clarification and the response shall be in writing, and no change in the prices or substance of the bid shall be sought, offered, or permitted.

24. Preliminary Examination

- 24.1 The Procuring agency will examine the bids to determine whether they are complete, whether any computational errors have been made, whether required sureties have been furnished, whether the documents have been properly signed, and whether the bids are generally in order.
- 24.2 Arithmetical errors will be rectified on the following basis. If there is a discrepancy between the unit price and the total price that is obtained by multiplying the unit price and quantity, the unit price shall prevail, and the total price shall be corrected. If the Supplier does not accept the correction of the errors, its bid will be rejected, and its bid security may be forfeited. If there is a discrepancy between words and figures, the amount in words will prevail.
- 24.3 The Procuring agency may waive any minor informality, nonconformity, or irregularity in a bid which does not constitute a material deviation, provided such waiver does not prejudice or affect the relative ranking of any Bidder.
- 24.4 Prior to the detailed evaluation, pursuant to ITB Clause 25 the Procuring agency will determine the substantial responsiveness of each bid to the bidding documents. For purposes of these Clauses, a substantially responsive bid is one which conforms to all the terms and conditions of the bidding documents without material deviations. Deviations from, or objections or reservations to critical provisions, such as those concerning Bid Security (ITB Clause 15), Applicable Law (GCC Clause 30), and Taxes and Duties (GCC Clause 32), will be deemed to be a material deviation. The Procuring agency's determination of a bid's responsiveness is to be based on the contents of the bid itself without recourse to extrinsic evidence.
- 24.5 If a bid is not substantially responsive, it will be rejected by the Procuring agency and may not subsequently be made responsive by the Bidder by correction of the nonconformity.

25. Evaluation and Comparison of Bids

- 25.1 The Procuring agency will evaluate and compare the bids which have been determined to be substantially responsive, pursuant to ITB Clause 24.
- 25.2 The Procuring agency's evaluation of a bid will be on delivered duty paid (DDP) price inclusive of prevailing taxes and duties and will exclude any allowance for price adjustment during the period of execution of the contract, if provided in the bid.
- 25.3 The Procuring agency's evaluation of a bid will take into account, in addition to the bid price quoted in accordance with ITB Clause 11.2, one or more of the following factors as specified in the Bid Data Sheet, and quantified in ITB Clause 25.4:
- a. incidental costs
 - b. delivery schedule offered in the bid;
 - c. deviations in payment schedule from that specified in the Special Conditions of Contract;
 - d. the cost of components, mandatory spare parts, and service (if any);
 - e. the availability Procuring agency of spare parts and after- sales services for the equipment offered in the bid (if any);
 - f. the projected operating and maintenance costs during the life of the equipment (if any);
 - g. the performance and productivity of the equipment offered; and/or
 - h. other specific criteria indicated in the Bid Data Sheet and/or in the Technical Specifications.
- 25.4 For factors retained in the Bid Data Sheet pursuant to ITB 25.3, one or more of the following quantification methods will be applied, as detailed in the Bid Data Sheet:
- a. Incidental costs provided by the bidder will be added by Procuring agency to the delivered duty paid (DDP) price at the final destination.
 - b. Delivery schedule.
 - (i) The Procuring agency requires that the goods under the Invitation for Bids shall be delivered at the time specified in the Schedule of Requirements, which will be treated as the base; a delivery "adjustment" will be calculated for bids by applying a percentage, specified in the Bid Data Sheet, of the DDP price for each week of delay beyond the base, and this will be added to the bid price for evaluation. No credit shall be given to early delivery; **or**
 - (ii) The goods covered under this invitation are required to be delivered (shipped) within an acceptable range of weeks specified in the Schedule of Requirement. No credit will be given to earlier deliveries, and bids offering delivery beyond this range will be treated as nonresponsive. Within this acceptable range, an adjustment per week, as specified in the Bid Data Sheet, will be added for evaluation to the bid price of bids offering deliveries later than the earliest delivery period specified in the Schedule of Requirements.
 - c. Deviation in payment schedule.
 - (i) Bidders shall state their bid price for the payment schedule outlined in the SCC. Bids will be evaluated on the basis of this base price. Bidders are, however, permitted to state an alternative payment schedule and indicate the reduction in bid price they wish to offer for such alternative payment schedule. The Procuring agency may consider the alternative payment schedule offered by the selected Bidder; **or**
 - (ii) The SCC stipulates the payment schedule offered by the Procuring agency. If a bid deviates from the schedule and if such deviation is

considered acceptable to the Procuring agency, the bid will be evaluated by calculating interest earned for any earlier payments involved in the terms outlined in the bid as compared with those stipulated in this invitation, at the rate per annum specified in the Bid Data Sheet.

- d. Specific qualification/evaluation criteria indicated in the Bid [Data Sheet and/or in the Technical Specifications. The relevant qualification/evaluation method shall be detailed in the Bid Data Sheet and/or in the Technical Specifications.

26. Contacting the Procuring agency

- 26.1 Subject to ITB Clause 23, no Bidder shall contact the Procuring agency on any matter relating to its bid, from the time of the bid opening to the time the contract is awarded. If the Bidder wishes to bring additional information to the notice of the Procuring agency, it should do so in writing.
- 26.2 Any effort by a Bidder to influence the Procuring agency in its decisions on bid evaluation, bid comparison, or contract award may result in the rejection of the Bidder's bid.

F. Award of Contract

27. Post-qualification

- 27.1 In the absence of prequalification, the Procuring agency will determine to its satisfaction whether the Bidder that is selected as having submitted the lowest evaluated responsive bid is qualified to perform the contract satisfactorily, in accordance with the criteria listed in ITB Clause 13.3.
- 27.2 The determination will take into account the Bidder's financial, technical, and production capabilities. It will be based upon an examination of the documentary evidence of the Bidder's qualifications submitted by the Bidder, pursuant to ITB Clause 13.3, as well as such other information as the Procuring agency deems necessary and appropriate.
- 27.3 An affirmative determination will be a prerequisite for award of the contract to the Bidder. A negative determination will result in rejection of the Bidder's bid, in which event the Procuring agency will proceed to the next lowest evaluated bid to make a similar determination of that Bidder's capabilities to perform satisfactorily.

28. Award Criteria

- 28.1 Subject to ITB Clause 30, the Procuring agency will award the contract to the successful Bidder whose bid has been determined to be substantially responsive and has been determined to be the most advantageous bid, provided further that the Bidder is determined to be qualified to perform the contract satisfactorily.

29. Procuring agency's Right to Vary Quantities at Time of Award

- 29.1 The Procuring agency reserves the right at the time of contract award to increase or decrease, the quantity of goods and services originally specified in the Schedule of Requirements without any change in unit price or other terms and conditions.

30. Procuring agency's Right to Accept any Bid and to Reject any or All Bids

- 30.1 The Procuring agency reserves the right to accept or reject any bid, and to annul the bidding process and reject all bids at any time prior to contract award, without thereby incurring any liability to the affected Bidder or bidders or any obligation to inform the affected Bidder or bidders of the grounds for the Procuring agency's action.

31. Notification of Award

- 31.1 Prior to the expiration of the period of bid validity, the Procuring agency will notify the successful Bidder in writing by registered letter or by cable, to be confirmed in writing by registered letter, that its bid has been accepted.
- 31.2 The notification of award will constitute the formation of the Contract.
- 31.3 Upon the successful Bidder's furnishing of the performance security pursuant to ITB Clause 33, the Procuring agency will promptly notify each unsuccessful Bidder and will discharge its bid security, pursuant to ITB Clause 15.

32. Signing of Contract

- 32.1 At the same time as the Procuring agency notifies the successful Bidder that its bid has been accepted, the Procuring agency will send the Bidder the Contract Form provided in the bidding documents, incorporating all agreements between the parties.
- 32.2 Within thirty (30) days of receipt of the Contract Form, the successful Bidder shall sign and date the contract and return it to the Procuring agency.

33. Performance Security

- 33.1 Within twenty (20) days of the receipt of notification of award from the Procuring agency, the successful Bidder shall furnish the performance security in accordance with the Conditions of Contract, in the Performance Security Form provided in the bidding documents, or in another form acceptable to the Procuring agency.
- 33.2 Failure of the successful Bidder to comply with the requirement of ITB Clause 32 or ITB Clause 33.1 shall constitute sufficient grounds for the annulment of the award and forfeiture of the bid security, in which event the Procuring agency may make the award to the next lowest evaluated Bidder or call for new bids.

34. Corrupt or Fraudulent Practices

- 34.1 The Government of Sindh requires that Procuring agency's (including beneficiaries of donor agencies' loans), as well as Bidders/Suppliers/Contractors under Government-financed or Procuring Agency-financed contracts, observe the highest standard of ethics during the procurement and execution of such contracts. In pursuance of this policy, the SPPRA, in accordance with the SPP Act, 2009 and Rules made thereunder:
- a. defines, for the purposes of this provision, the terms set forth below as follows:
 - i. "corrupt practice" means the offering, giving, receiving or soliciting of anything of value to influence the action of a public official in the procurement process or in contract execution; and
 - ii. "fraudulent practice" means a misrepresentation of facts in order to influence a procurement process or the execution of a contract to the detriment of the Procuring agency, and includes collusive practice among Bidders (prior to or after bid submission) designed to establish bid prices at artificial non- competitive levels and to deprive the Procuring agency of the benefits of free and open competition;

- b. will reject a proposal for award if it determines that the Bidder recommended for award has engaged in corrupt or fraudulent practices in competing for the contract in question;
 - c. will declare a firm ineligible, either indefinitely or for a stated period of time, to be awarded a Government-financed contract if it at any time determines that the firm has engaged in corrupt or fraudulent practices in competing for, or in executing, a Government-financed contract.
- 34.2 Furthermore, Bidders shall be aware of the provision stated in sub-clause 5.4 and sub-clause 24.1 of the General Conditions of Contract.

35. Integrity Pact

- 35.1 The bidder shall sign and stamp the Integrity Pact provided in the "Sample Forms" Section of these bidding documents for all Provincial Government procurement contracts. Failure to such Integrity Pact shall make the bidder non-responsive

Part One - Section II
General Conditions of Contract

General Conditions of Contract

1. Definitions

1.1 In this Contract, the following terms shall be interpreted as indicated:

- a. "The Contract" means the agreement entered into between the Procuring agency and the Supplier, as recorded in the Contract Form signed by the parties, including all attachments and appendices thereto and all documents incorporated by reference therein.
- b. "The Contract Price" means the price payable to the Supplier under the Contract for the full and proper performance of its contractual obligations.
- c. "The Goods" means all of the equipment, machinery, and/or other materials which the Supplier is required to supply to the Procuring agency under the Contract.
- d. "The Services" means those services ancillary to the supply of the Goods, such as transportation and insurance, and any other incidental services, such as installation, commissioning, provision of technical assistance, training, and other such obligations of the Supplier covered under the Contract.
- e. "GCC" means the General Conditions of Contract contained in this section.
- f. "SCC" means the Special Conditions of Contract.
- g. "The Procuring agency" means the organization purchasing the Goods, as named in SCC.
- h. "The Procuring agency's country" is the country named in SCC.
- i. "The Supplier" means the individual or firm supplying the Goods and Services under this Contract.
- j. "The Project Site," where applicable, means the place or places named in SCC.
- k. "Day" means calendar day.
- l. "Envelope" means encrypted electronic file.

2. Application

2.1 These General Conditions shall apply to the extent that they are not superseded by provisions of other parts of the Contract.

3. Country of Origin

3.1 All Goods and Services supplied under the Contract shall have their origin in the countries and territories eligible under the rules and further elaborated in the SCC or Technical Specifications.

3.2 For purposes of this Clause, "origin" means the place where the Goods were mined, grown, or produced, or from which the Services are supplied. Goods are produced when, through manufacturing, processing, or substantial and major assembly of components, a commercially recognized new product results that is substantially different in basic characteristics or in purpose or utility from its components.

3.3 The origin of Goods and Services is distinct from the nationality of the Manufacturer / Supplier.

4. Technical Specifications

- 4.1 The Goods supplied under this Contract shall conform to the standards mentioned in the Technical Specifications, and, when no applicable standard is mentioned, to the authoritative standards appropriate to the Goods' country of origin. Such standards shall be the latest issued by the concerned institution.

5. Use of Contract Documents and Information; Inspection and Audit by the Government

- 5.1 The Supplier shall not, without the Procuring agency's prior written consent, disclose the Contract, or any provision thereof, or any specification, plan, drawing, pattern, sample, or information furnished by or on behalf of the Procuring agency in connection therewith, to any person other than a person employed by the Supplier in the performance of the Contract. Disclosure to any such employed person shall be made in confidence and shall extend only so far as may be necessary for purposes of such performance.
- 5.2 The Supplier shall not, without the Procuring agency's prior written consent, make use of any document or information enumerated in GCC Clause 5.1 except for purposes of performing the Contract.
- 5.3 Any document, other than the Contract itself, enumerated in GCC Clause 5.1 shall remain the property of the Procuring agency and shall be returned (all copies) to the Procuring agency on completion of the Supplier's performance under the Contract if so required by the Procuring agency.
- 5.4 The Supplier shall permit the Procuring agency to inspect the Supplier's accounts and records relating to the performance of the Supplier and to have them audited by auditors appointed by the procuring agency, if so required.

6. Patent Rights

- 6.1 The Supplier shall indemnify the Procuring agency against all third-party claims of infringement of patent, trademark, or industrial design rights arising from use of the Goods or any part thereof in the Procuring agency's country.

7. Performance Security

- 7.1 Within twenty (20) days of receipt of the notification of Contract award, the successful Bidder shall furnish to the Procuring agency the performance security in the amount specified in SCC.
- 7.2 The proceeds of the performance security shall be payable to the Procuring agency as compensation for any loss resulting from the Supplier's failure to complete its obligations under the Contract.
- 7.3 The performance security shall be denominated in the currency of the Contract acceptable to the Procuring agency and shall be in one of the following forms:
- a. a bank guarantee or an irrevocable letter of credit issued by a reputable bank located in the Procuring agency's country, in the form provided in the bidding documents or another form acceptable to the Procuring agency; or
 - b. a cashier's or certified check.
- 7.4 The performance security will be discharged by the Procuring agency and returned to the Supplier not later than thirty (30) days following the date of completion of the Supplier's performance obligations under the Contract, including any warranty obligations, unless specified otherwise in SCC.

8. Inspections and Tests

- 8.1 The Procuring agency or its representative shall have the right to inspect and/or to test the Goods to confirm their conformity to the Contract specifications at no extra cost to the Procuring agency. SCC and the Technical Specifications shall specify what inspections and tests the Procuring agency requires and where they are to be conducted. The Procuring agency shall notify the Supplier in writing, in a timely manner, of the identity of any representatives retained for these purposes.
- 8.2 The inspections and tests may be conducted on the premises of the Supplier or its subcontractor(s), at point of delivery, and/or at the Goods' final destination. If conducted on the premises of the Supplier or its subcontractor(s), all reasonable facilities and assistance, including access to drawings and production data, shall be furnished to the inspectors at no charge to the Procuring agency
- 8.3 Should any inspected or tested Goods fail to conform to the Specifications, the Procuring agency may reject the Goods, and the Supplier shall either replace the rejected Goods or make alterations necessary to meet specification requirements free of cost to the Procuring agency.
- 8.4 The Procuring agency's right to inspect, test and, where necessary, reject the Goods after the Goods' arrival in the Procuring agency's country shall in no way be limited or waived by reason of the Goods having previously been inspected, tested, and passed by the Procuring agency or its representative prior to the Goods' shipment from the country of origin.
- 8.5 Nothing in GCC Clause 8 shall in any way release the Supplier from any warranty or other obligations under this Contract.

9. Packing

- 9.1 The Supplier shall provide such packing of the Goods as is required to prevent their damage or deterioration during transit to their final destination, as indicated in the Contract. The packing shall be sufficient to withstand, without limitation, rough handling during transit and exposure to extreme temperatures, salt and precipitation during transit, and open storage. Packing case size and weights shall take into consideration, where appropriate, the remoteness of the Goods' final destination and the absence of heavy handling facilities at all points in transit.
- 9.2 The packing, marking, and documentation within and outside the packages shall comply strictly with such special requirements as shall be expressly provided for in the Contract, including additional requirements, if any, specified in SCC, and in any subsequent instructions ordered by the Procuring agency.

10. Delivery and Documents

- 10.1 Delivery of the Goods shall be made by the Supplier in accordance with the terms specified in the Schedule of Requirements. The details of shipping and/or other documents to be furnished by the Supplier are specified in SCC.
- 10.2 Documents to be submitted by the Supplier are specified in SCC.

11. Insurance

- 11.1 The Goods supplied under the Contract shall be delivered duty paid (DDP) / CFR / CNF / C&F / CPT – Karachi under which risk is transferred to the buyer after having been delivered at consignees end or Karachi Port, hence insurance coverage is sellers responsibility.

12. Transportation

- 12.1 The Supplier is required under the Contract to transport the Goods to a specified place of destination outside and within the Procuring agency's country, transport to such place of destination in the Procuring agency's country, including insurance and storage, as shall be specified in the Contract, shall be arranged by the Supplier, and related costs shall be included in the Contract Price.

13. Incidental Services

- 13.1 The Supplier may be required to provide any or all of the following services, including additional services, if any, specified in SCC:
- a. performance or supervision of on-site assembly and/or start-up of the supplied Goods;
 - b. furnishing of tools required for assembly and/or maintenance of the supplied Goods;
 - c. furnishing of a detailed operations and maintenance manual for each appropriate unit of the supplied Goods;
 - d. performance or supervision or maintenance and/or repair of the supplied Goods, for a period of time agreed by the parties, provided that this service shall not relieve the Supplier of any warranty obligations under this Contract; and
 - e. training of the Procuring agency's personnel, at the Supplier's plant and/or on-site, in assembly, start-up, operation, maintenance, and/or repair of the supplied Goods.
- 13.2 Prices charged by the Supplier for incidental services, if not included in the Contract Price for the Goods, shall be agreed upon in advance by the parties and shall not exceed the prevailing rates charged for other parties by the Supplier for similar services.

14. Warranty

- 14.1 The Supplier warrants that the Goods supplied under the Contract are new, unused, of the most recent or current models, and that they incorporate all recent improvements in design and materials unless provided otherwise in the Contract. The Supplier further warrants that all Goods supplied under this Contract shall have no defect, arising from design, materials, or workmanship (except when the design and/or material is required by the Procuring agency's specifications) or from any act or omission of the Supplier, that may develop under normal use of the supplied Goods in the conditions prevailing in the country of final destination.
- 14.2 This warranty shall remain valid for twelve (12) months or according to the requirement of extended warranty period after the Goods, or any portion thereof as the case may be, have been delivered to and accepted at the final destination indicated in the Contract. In any case this period shall not exceed six (06) months beyond the warranty expiration period from the date of taking over of goods by the procuring agency, unless specified otherwise in SCC.
- 14.3 The Procuring agency shall promptly notify the Supplier in writing of any claims arising under this warranty.
- 14.4 Upon receipt of such notice, the Supplier shall, within the period specified in SCC and with all reasonable speed, repair or replace the defective Goods or parts thereof, without costs to the Procuring agency.
- 14.5 If the Supplier, having been notified, fails to remedy the defect(s) within the period specified in SCC, within a reasonable period, the Procuring agency may proceed to take such remedial action as may be necessary, at the Supplier's risk and expense and without prejudice to any other rights which the Procuring agency may have against the Supplier under the Contract.
- 14.6 The provisions of this Clause include all the expenses that the bidder may have to incur for delivery and installation of such replacement parts, material and equipment as are needed for satisfactory operation of the goods at the consignees end.
- 14.7 During the period of warranty, the bidder shall remedy, at his / her expense all defects in design, material and workmanship that may develop or are revealed under normal use of the

goods upon receiving writing notice from the procuring agency; the notice shall indicate in what respect the goods are faulty.

- 14.8 The bidder shall provide warranty / guarantee for supply of reagents, kits and chemicals, consumables, films and ancillaries for at least 10 years (where applicable).
- 14.9 The bidder shall remain responsible for providing after sale services even after expiry of warranty / guarantee period and sign a Service Contract including parts or without parts with Procuring Agency for 05 years (minimum). Bidder shall separately quote the price of service contract (in terms of percentage) inclusive of parts and without parts, separately.
- 14.10 In case of consumable items, reagents, kits, chemicals, films etc. the contractor shall remain responsible for specificity, efficacy & sensitivity with maximum period of expiry as much allowed by manufacturer.
- 14.11 The Procuring Agency shall promptly notify the Bidder in writing of any claims arising out of this warranty.
- 14.12 The bidder shall be responsible to ensure the 95% uptime of the machinery / equipment during the warranty period.

15. Payment

- 15.1 The method and conditions of payment to be made to the Supplier under this Contract shall be specified in SCC.
- 15.2 The Supplier's request(s) for payment shall be made to the Procuring agency in writing, accompanied by an invoice describing, as appropriate, the Goods delivered and Services performed, and by documents submitted pursuant to GCC Clause 10, and upon fulfillment of other obligations stipulated in the Contract.
- 15.3 Payments shall be made promptly by the Procuring agency, but in no case later than ninety (90) days after submission of an invoice or claim by the Supplier.
- 15.4 The currency of payment shall be in Pak. Rupees.

16. Prices

- 16.1 Prices charged by the Supplier for Goods delivered and Services performed under the Contract shall not vary from the prices quoted by the Supplier in its bid, with the exception of any price adjustments authorized in SCC or in the Procuring agency's request for bid validity extension, as the case may be.

17. Change Orders

- 17.1 The Procuring agency may at any time, by a written order given to the Supplier pursuant to GCC Clause 31, make changes within the general scope of the Contract in any one or more of the following:
 - a. drawings, designs, or specifications, where Goods to be furnished under the Contract are to be specifically manufactured for the Procuring agency;
 - b. the method of shipment or packing;
 - c. the place of delivery; and/or
 - d. the Services to be provided by the Supplier.
- 17.2 If any such change causes an increase or decrease in the cost of, or the time required for, the Supplier's performance of any provisions under the Contract, an equitable adjustment shall be made in the Contract Price or delivery schedule, or both, and the Contract shall accordingly be amended. Any claims by the Supplier for adjustment under this clause must be asserted within thirty (30) days from the date of the Supplier's receipt of the Procuring agency's change order.

18. Contract Amendments

- 18.1 Subject to GCC Clause 18, no variation in or modification of the terms of the Contract shall be made except by written amendment signed by the parties.

19. Assignment

- 19.1 The Supplier shall not assign, in whole or in part, its obligations to perform under this Contract, except with the Procuring agency's prior written consent.

20. Subcontracts

- 20.1 The Supplier shall not be allowed to sublet and award subcontracts under this Contract.

21. Delay in the Supplier's Performance

- 21.1 Delivery of the Goods and performance of Services shall be made by the Supplier in accordance with the time schedule prescribed by the Procuring agency in the Schedule of Requirements / Contract Award.
- 21.2 If at any time during performance of the Contract, the Supplier or its subcontractor(s) should encounter conditions impeding timely delivery of the Goods and performance of Services, the Supplier shall promptly notify the Procuring agency in writing of the fact of the delay, its likely duration and its cause(s). As soon as practicable after receipt of the Supplier's notice, the Procuring agency shall evaluate the situation and may at its discretion extend the Supplier's time for performance, with or without liquidated damages, in which case the extension shall be ratified by the parties by amendment of Contract.
- 21.3 Except as provided under GCC Clause 25, a delay by the Supplier in the performance of its delivery obligations shall render the Supplier liable to the imposition of liquidated damages pursuant to GCC Clause 23, unless an extension of time is agreed upon pursuant to GCC Clause 22.2 without the application of liquidated damages.

22. Liquidated Damages

- 22.1 Subject to GCC Clause 25, if the Supplier fails to deliver any or all of the Goods or to perform the Services within the period(s) specified in the Contract, the Procuring agency shall, without prejudice to its other remedies under the Contract, deduct from the Contract Price, as liquidated damages, a sum equivalent to the percentage specified in SCC of the delivered price of the delayed Goods or unperformed Services for each week or part thereof of delay until actual delivery or performance, up to a maximum deduction of the percentage specified in SCC. Once the maximum is reached, the Procuring agency may consider termination of the Contract pursuant to GCC Clause 24.

23. Termination for Default

- 23.1 The Procuring agency, without prejudice to any other remedy for breach of Contract, by written notice of default sent to the Supplier, may terminate this Contract in whole or in part:
- a. if the Supplier fails to deliver any or all of the Goods within the period(s) specified in the Contract, or within any extension thereof granted by the Procuring agency pursuant to GCC Clause 22; or
 - b. if the Supplier fails to perform any other obligation(s) under the Contract.
 - c. if the Supplier, in the judgment of the Procuring agency has engaged in corrupt or fraudulent practices in competing for or in executing the Contract.

For the purpose of this clause:

“corrupt practice” means the offering, giving, receiving or soliciting of any thing of value to influence the action of a public official in the procurement process or in contract execution.

“fraudulent practice” means a misrepresentation of facts in order to influence a procurement process or the execution of a contract to the detriment of the Borrower, and includes collusive practice among Bidders (prior to or after bid submission) designed to establish bid prices at artificial non-competitive levels and to deprive the Borrower of the benefits of free and open competition.

- 23.2 In the event the Procuring agency terminates the Contract in whole or in part, pursuant to GCC Clause 24.1, the Procuring agency may procure, upon such terms and in such manner as it deems appropriate, Goods or Services similar to those undelivered, and the Supplier shall be liable to the Procuring agency for any excess costs for such similar Goods or Services. However, the Supplier shall continue performance of the Contract to the extent not terminated.

24. Force Majeure

- 24.1 Notwithstanding the provisions of GCC Clauses 22, 23, and 24, the Supplier shall not be liable for forfeiture of its performance security, liquidated damages, or termination for default if and to the extent that its delay in performance or other failure to perform its obligations under the Contract is the result of an event of Force Majeure.

- 24.2 For purposes of this clause, “Force Majeure” means an event beyond the control of the Supplier and not involving the Supplier’s fault or negligence and not foreseeable. Such events may include, but are not restricted to, acts of the Procuring agency in its sovereign capacity, wars or revolutions, fires, floods, epidemics, quarantine restrictions, and freight embargoes.

- 24.3 If a Force Majeure situation arises, the Supplier shall promptly notify the Procuring agency in writing of such condition and the cause thereof. Unless otherwise directed by the Procuring agency in writing, the Supplier shall continue to perform its obligations under the Contract as far as is reasonably practical, and shall seek all reasonable alternative means for performance not prevented by the Force Majeure event.

25. Termination for Insolvency

- 25.1 The Procuring agency may at any time terminate the Contract by giving written notice to the Supplier if the Supplier becomes bankrupt or otherwise insolvent. In this event, termination will be without compensation to the Supplier, provided that such termination will not prejudice or affect any right of action or remedy which has accrued or will accrue thereafter to the Procuring agency.

26. Termination for Convenience

- 26.1 The Procuring agency, by written notice sent to the Supplier, may terminate the Contract, in whole or in part, at any time for its convenience. The notice of termination shall specify that termination is for the Procuring agency’s convenience, the extent to which performance of the Supplier under the Contract is terminated, and the date upon which such termination becomes effective.

- 26.2 The Goods that are complete and ready for shipment within thirty (30) days after the Supplier’s receipt of notice of termination shall be accepted by the Procuring agency at the Contract terms and prices. For the remaining Goods, the Procuring agency may elect:

- a. to have any portion completed and delivered at the Contract terms and prices; and/or
- b. to cancel the remainder and pay to the Supplier an agreed amount for partially completed Goods and Services and for materials and parts previously procured by the Supplier.

27. Resolution of disputes

- 27.1 The Procuring agency and the Supplier shall make every effort to resolve amicably by direct informal negotiation any disagreement or dispute arising between them under or in connection with the Contract.
- 27.2 If, after thirty (30) days from the commencement of such informal negotiations, the Procuring agency and the Supplier have been unable to resolve amicably a Contract dispute, either party may require that the dispute be referred for resolution to the formal mechanisms specified in SCC. These mechanisms may include, but are not restricted to, conciliation mediated by a third party, adjudication in an agreed manner and/or arbitration.

28. Governing Language

- 28.1 The Contract shall be written in the language specified in SCC. Subject to GCC Clause 30, the version of the Contract written in the specified language shall govern its interpretation. All correspondence and other documents pertaining to the Contract which are exchanged by the parties shall be written in the same language.

29. Applicable Law

- 29.1 The Contract shall be interpreted in accordance with the laws of the Procuring agency's country (Islamic Republic of Pakistan), unless otherwise specified in SCC.

30. Notices

- 30.1 Any notice given by one party to the other pursuant to this Contract shall be sent to the other party in writing or by cable, telex, or facsimile and confirmed in writing to the other party's address specified in SCC.
- 30.2 A notice shall be effective when delivered or on the notice's effective date, whichever is later.

31. Taxes and Duties

- 31.1 Supplier shall be entirely responsible for all taxes, duties, license fees, etc. (excluding GST), incurred until delivery of the contracted Goods to the Procuring agency in case of Delivered Duty Paid (DDP) basis.

Part Two (Procurement Specific Provisions)

- Invitation for Bids (IFB)
- Bid Data Sheet (BDS)
- Special Conditions of Contract (SCC)
- Schedule of Requirements
- Technical Specifications
- Sample Form
- Eligibility

Part Two - Section I
Invitation for Bids

Invitation for Bids (IFB) / Notice Inviting Tender (NIT) No. DUHS/DP/2026/343-344 Dated 13 May 2026

Dow University of Health Sciences, Karachi (DUHS) invites e-bids through E-Pak Acquisition and Disposal System (EPADS) from the manufacturers or their authorized agents / distributors / firms. Bidders must be register and appear on the 'List of Active Taxpayers' of FBR/SRB for income tax and GST/SST (whichever is applicable) for the supply of following categories/items/goods and Ancillary Services at DOW University of Health Sciences, Karachi". Bidding Documents containing detailed Terms and Conditions can be viewed/downloaded from <https://portalsindh.eprocure.gov.pk/#/> OR <https://duhs.edu.pk>.

Electronic bids should be submitted through EPADS only. Manual bids will not be received/entertained. Interested bidders are required to register themselves on the EPAD System at the link <https://sindh.eprocure.gov.pk/#/supplier/registration> for submission of electronic bids.

The bids, prepared according to the instructions provided in the bidding documents, must be submitted on EPADS by **16 June 2026 at 11:00 Hrs.** The original instrument of the **tender fee of Rs. 2,000/-** (Non-refundable) and **bid security not less than mentioned percent (%) of the estimated value of the tender OR item / group** as per following details must be reach the procuring agency (Procurement Directorate at Central Warehouse, Dow University of Health Sciences (Ojha Campus), SUPARCO Road, off Main University Road, Gulzar-e-Hijri, Scheme No. 33, Karachi) before the deadline for submission of e-bids, which will be opened on the same day at **11:30 Hrs.**

S#	Category	Tender Reference Number	Amount of Bid Security
1.	Procurement of Papers, Stationary, General & IT Consumable, Printing Material, IT Hardware & Network Items. <i>DDP Basis (Excluding GST)</i> Single Stage – One Envelope Procedure under Rule 46(1) of SPP Rules 2010, on rate contract basis.	DUHS/DP/2026/343	Amount indicated against each item in Section V of Bidding Documents (2% of Estimated Cost)
2.	Procurement of Furniture/ Fixtures for Construction of Seminar Hall <i>DDP Basis (Excluding GST)</i> Single Stage – One Envelope Procedure under Rule 46(1) of SPP Rules 2010.	DUHS/DP/2026/344	Amount indicated against each group in Section V of Bidding Documents (2% of Estimated Cost)

Note:

- a. For any query regarding e-bidding, please contact the Director Procurement Office at Tel: 021-38771111 (Ext. 4433)
- b. In case Govt. announces any public holiday or any unfavorable circumstances the tender/bids will be submitted and opened on the next working day, at the same venue and time.
- c. The purchaser reserves the right to reject any/all bids under the relevant provisions of SPP Rules 2010 (Amended).
- d. In case of any difficulty, prospective bidders may contact the EPADS Helpline 051-111-137-237 during working days/hours.

**Director Procurement
Dow University of Health Sciences, Karachi**

Part Two - Section II
Bid Data Sheet

Bid Data Sheet

The following specific data for the goods to be procured shall complement, supplement, or amend the provisions in the Instructions to Bidders (ITB) Part One. Whenever there is a conflict, the provisions herein shall prevail over those in ITB.

Introduction	
ITB 1.1	Name of Procuring Agency: Dow University of Health Sciences, Karachi (DUHS)
ITB 1.1	Project / Scheme / Tender Allocation Amount: PKR. 146.912 million
ITB 1.1	Project / Scheme Allocation Number
ITB 1.1	Name of Project/Scheme: Procurement of Furniture/ Fixtures for Construction of Seminar Hall, Ojha Campus of Dow University of Health Sciences, Karachi.
ITB 1.1	Name of Contract: Procurement of Furniture/ Fixtures for Construction of Seminar Hall, Ojha Campus of Dow University of Health Sciences, Karachi.
ITB 2.4	Bids submitted under Joint Venture (JV) / Consortium will not be considered and rejected as ineligible bidder.
ITB 4.1	Name of Procuring agency: Dow University of Health Sciences, Karachi (DUHS)
ITB 6.1	Postal Address: Procurement Directorate at Central Warehouse, Dow University of Health Sciences (Ojha Campus), SUPARCO Road, off Main University Road, Gulzar-e-Hijri, Scheme No. 33, Karachi. Phone No. + 92-21-99261497, Ext: 4433. Email: director.procurement@duhs.edu.pk
ITB 8.1	Language of the bid shall be ENGLISH.

Bid Price and Currency	
ITB 11.2	<ul style="list-style-type: none"> • The price quoted shall be in Pakistani Rupee on delivered duty paid (DDP) Price (excluding GST). • Price of incidental services, if any, must be included in price of goods.
ITB 11.4	The price shall be fixed during the contract period with the exception of price adjustment authorized in SCC.
ITB 12.1	The price quoted shall be in Pak Rupees on delivered duty paid (DDP) basis (Excluding GST) .

Preparation and Submission of Bids	
ITB 13.3 (d)	Mandatory Qualification requirements Please review the following list of requirements/ documents to be enclosed with the Technical Proposal. These are the “MANDATORY REQUIREMENTS/DOCUMENTS” non-submission of any one of the mandatory documents / non-compliance to the any single mandatory provision will lead to disqualification / rejection of the bid.

Preparation and Submission of Bids		
ITB 13.3 (d)	Mandatory Qualification requirements Please review the following list of requirements/ documents to be enclosed with the Technical Proposal. These are the “ MANDATORY REQUIREMENTS/DOCUMENTS ”, non-submission of any one of the mandatory documents / non-compliance to the any single mandatory provision will lead to disqualification / rejection of the bid.	
S#	DOCUMENT OF PARTICIPATING FIRM	YES / NO
1.	PRODUCT EVALUATION	
1.1	Sample of all the Items must be submitted prior to the opening of bid	
1.2	Compliance with Technical Specifications / Approval of the Samples	
1.3	Technical Bid / Proposal duly signed and stamped (preferably on Bidder's letterhead).	
1.4	Catalogue / Brochures / Technical Data Sheet / Sketches / Drawings duly highlighting the complete technical specifications of the offered goods along with the dimensions and details of material.	
1.5	Valid Manufacturer Authorization in accordance with ITB Clause 11.1(a) NOTE: - a. Only Manufacturer of the Furniture & Fixtures OR Authorized Sole Agent of Manufacturer of the Chairs (with Original Authorization Letter) can participate in the bidding process. b. Valid Factory Registration Certificate issued by the competent authority/ Principal Activity Registered in FBR as Manufacturer of Furniture and ISO 9001: 2015 Certificate as/of the manufacturer must be attached. c. The production facility/factory must have a minimum covered area of 20,000 square feet. Documentary proof of the facility/factory size must be submitted/attached, and the location will also be physically visited for verification. d. The manufacturing/production facility must be under the ownership of the bidder/company, and documentary evidence of ownership must be submitted/attached. e. Transportation vehicles such as Shehzore, Sukuzi Bolan must be under the ownership of the bidder/company, and documentary evidence of ownership must be submitted/attached. f. Detailed information of the imported machinery , i.e., PVC lipping machine, 360 cutter, and hydraulic press, along with real images and purchase documents, must be submitted/attached. The machinery will also be physically checked at the factory. g. JV / SUB-DISTRIBUTOR / SPOT AUTHORIZED AGENT is not allowed to participate in the bidding process.	
2.	BIDDER EVALUATION	
2.1	Tender Purchase Receipt / Pay order of Tender Fee.	
2.2	Bid Security of required amount and in prescribed shape. (Must be submitted before the opening of the bids)	
2.3	Bidding Documents (Duly filled, Signed & Stamped by Bidder)	
2.4	Undertaking on stamp paper of Rs. 100/- to the effect that: i. The bidder is neither blacklisted nor suspended by any National/ International, including Provincial and Federal Government. ii. Any director or owner of the bidding company is not awarded any punishment by any Court of Law.	

	<p>iii. Bidder has submitted the correct and complete information along with the bid/offer. If any document / information is found forged / engineered / fake / bogus at any stage, the bidder may be declared as Blacklisted in accordance with law and the performance guarantee and payment, if any may be forfeited.</p> <p>(Note: The offers from the bidder whose name have been removed from the blacklist will be accepted.)</p>	
2.5	Compliance with bid validity period.	
2.6	Compliance with Delivery Schedule.	
2.7	Compliance with Payment Terms & Conditions.	
2.8	Income Tax & GST/SST Registration (whichever is applicable) with Active Taxpayer Status on FBR/SRB website	
2.9	Bid Form on Bidder's Letterhead duly signed and stamped.	
2.10	Price Schedule(s) on Bidder's Letterhead duly signed and stamped.	
2.11	Warranty Certificate from Bidder for Wooden Furniture being Termite-free for at least 3 years from the date of delivery.	
2.12	<p>Past Experience / Performance: The bidder must have successfully completed or ongoing minimum one (01) contract/project/purchase order of supply of furniture & fixtures, with a cumulative value of not less than PKR 118 million, during the last five (05) years, to any reputable Public / Private Sector Organization or NPO's duly registered with Exchange Commission of Pakistan (SECP). Verifiable documentary evidence in support of the same must be furnished with the bid.</p> <p style="text-align: center;">OR</p> <p>Bidder must had completed or ongoing minimum Two project (02) Contract / Project / Purchase order / Supply order valuing PKR 73 million or above for supplying the Furniture / Fixture to any Government / Private Sector Organization or NPO's duly registered with Exchange Commission of Pakistan (SECP) during last 5 years.</p>	
2.13	Bidder's Financial Strength: Average Annual Turnover of the last five (05) financial years must not be less than PKR 100 million (Income Tax Returns for the last 3 years must be attached as supporting documents for the verification of the turnover).	
2.14	Company Profile	

ITB 15.1	Amount of bid security not less than mentioned percent (%) of the estimated value of the tender OR group / lot in the form of a Call Deposit, Bank Draft or a Bank Guarantee issued by a scheduled bank of Pakistan, in favour of the Dow University of Health Sciences, Karachi.
ITB 16.1	Bid validity period shall be 90 days
ITB 18.2 (a)	<p>a. Procurement Directorate at Central Warehouse, Dow University of Health Sciences (Ojha Campus), SUPARCO Road, off Main University Road, Gulzar-e-Hijri, Scheme No. 33, Karachi.</p> <p>b. Electronic Bids should be submitted through E-Pak Acquisition and Disposable System (EPADS).</p>

ITB 18.2 (b)	<p>Name of Project / Scheme / Institute / Department: Procurement of Furniture/ Fixtures for Construction of Seminar Hall, Ojha Campus of Dow University of Health Sciences, Karachi.</p> <p>IFB/NIT. Title: Procurement of Furniture/ Fixtures for Construction of Seminar Hall (Ref. No: DUSH/DP/2026/344)</p> <p>IFB/NIT. No: DUHS/DP/2026/343-344 Dated 13 May 2026</p>
ITB 19.1	<p>Electronic Bids should be submitted through E-Pak Acquisition and Disposable System (EPADS)</p> <p>Deadline for bid submission: Date: 16 June 2026 Time: upto 11:00 Hrs.</p>
ITB 21.3	<p>All supporting documents pertaining to the Mandatory Bidder's Qualification and Evaluation Criteria, as required under these Bidding Documents, must be uploaded exclusively on the SPPRAL (EPADS) portal. No clarification or document submitted in any other form or medium will be accepted or entertained after the opening of bids on EPADS.</p>
ITB 22.1	<p>Date, Time and Place of Bid Opening Date: 16 June 2026 Time: 11:30 Hrs. Place: Procurement Directorate at Central Warehouse, Dow University of Health Sciences (Ojha Campus), SUPARCO Road, off Main University Road, Gulzar-e-Hijri, Scheme No. 33, Karachi.</p>
ITB 24.5	<p>Bidders shall provide firm, clear, and unconditional responses in their bids. The use of vague, ambiguous, or conditional expressions such as "<i>subject to,</i>" "<i>may be,</i>" "<i>between this and that,</i>" or any similar terminology is strictly prohibited and may result in the bid being declared non-responsive in accordance with the applicable procurement rules.</p>

Bid Evaluation	
ITB 25.4	Criteria for bid evaluation.

i. Technical Bids / Proposals Evaluation:

- (a) The bids not responsive to the MANDATORY QUALIFICATION CRITERIA provided at ITB Clause 13.3(d) shall not be eligible for further Technical Evaluation.
- (b) Joint Venture / Consortium Bids, Vague Bids, Ambiguous Bids, Conditional Bids, Telegraphic Bids, Bids not accompanied by Bid Security of required amount and form, bids received after specific date and time and bids of Blacklisted firms shall be treated as rejected / non-responsive (The offers from the bidder whose name have been removed from the blacklist will be accepted).
- (c) Alternative bids shall not be allowed.
- (d) The bids shall be evaluated and compared on a **complete Group / Lot / Package basis only**, as specified in Section V – Technical Specifications. Partial or incomplete bids covering limited item(s) within a Group / Lot / Package shall not be considered and shall be rejected as non-responsive.
- (e) DUHS may reject the bid/or part of it if previous experience in terms of supplies and service is not satisfactory.

ii. **Financial Bids / Proposal Evaluation:**

- a. Financial Bids/Proposals of only technically qualified bidders meeting the eligibility criteria shall be considered for the evaluation.
- b. Bids not accompanied by the Bid Security of the required amount and form shall be rejected.
- c. Procuring Agency shall not be responsible for any erroneous calculation of taxes and all differences arising out shall be fully borne by the Successful Bidder.
- d. The bidder whose offered rate is found lowest amongst other technically qualified bidders shall be considered for acceptance of the offer provided that it fulfils the prescribed terms and conditions of the tender.

Contract Award	
ITB 29.1	The Procuring Agency reserves the right to drop any item and/or to increase or decrease the quantity of goods, up to fifteen percent (±15%) of the originally specified quantity, without any change in unit price or other terms and conditions of the contract.
ITM 32.1	Successful Bidder and the Procuring Agency will sign the Contract Agreement on the stamp paper with stamp duties as per the article 22-A (Contract) of the schedule of Stamp Act 1899. The expenditure involved on the said contract agreement will be borne by the bidder.

Part Two - Section III
Special Conditions of Contract

Special Conditions of Contract

The following Special Conditions of Contract shall supplement the General Conditions of Contract. Whenever there is a conflict, the provisions herein shall prevail over those in the General Conditions of Contract. The corresponding clause number of the GCC is indicated in parentheses.

1. Definitions (GCC Clause 1)

GCC 1.1 (g)—The Procuring agency is: Dow University of Health Sciences, Karachi.

GCC 1.1 (h)—The Procuring agency's country is: Islamic Republic of Pakistan

GCC 1.1 (i)—The Supplier is: _____
[Name and Address of the Bidder]

2. Country of Origin (GCC Clause 3)

All countries and territories as indicated in Part Two Section VI of the bidding documents, "Eligibility for the Provisions of Goods, Works, and Services in Government-Financed Procurement".

3. Technical Specifications (GCC Clause 4)

The technical specifications of the goods provided in this bidding document are only for widest possible competition and not for favor any single contractor or supplier nor put others at a disadvantage. However, the brand name, catalogue No. / Name etc., if any, has only been used for the reference purpose. Equipment offered "**ATLEAST EQUIVALENT OR HAVING BETTER TECHNICAL SPECIFICATIONS**" shall also be considered.

4. Performance Security (GCC Clause 7)

GCC 7.1—The amount of performance security, as a percentage of the Contract Price, shall be **Five (5%) percent** of the Contract Price in favor of Dow University of Health Sciences, Karachi.

5. Packing (GCC Clause 9)

GCC 9.2—The following SCC shall supplement GCC Clause 9.2:

The packing, marking and documentation within and outside the packages shall be as per manufacturer standards meeting the safety requirements of the goods.

6. Delivery and Documents (GCC Clause 10)

GCC 10.2—The Bidder shall provide the following documents at the time of delivery of goods to the Store / Warehouse of the Dow University of Health Sciences, Karachi for verification duly completed in all respects:

- i. Original copies of Delivery Note (Delivery Challan) (in duplicate) showing item's description, make, model, quantity as well as Lot Number, Batch Number, Registration Number, manufacturing and expiry dates (if applicable).
- ii. Original copies of the Bidder's invoices (in duplicate) showing warranty, item's description, make, model as well as Lot Number, Batch Number, Registration Number, manufacturing and expiry dates (if applicable) per unit cost, and total amount.
- iii. Original copies of the Sales Tax Invoices (where applicable) in duplicate showing item's description, quantity, per unit cost without Sales Tax, amount of Sales Tax and total amount with Sales Tax.
- iv. Manufacturer's or Bidder's warranty certificate.
- v. Inspection certificate issued by the nominated inspection committee / Bidder's factory inspection report.

- vi. Certificate of origin.
- vii. Operator manual, technical and service manual, software, spare parts catalogue and price list must be provided with the equipment **(If applicable)**.

7. Insurance (GCC Clause 11)

GCC 11.1—The Goods supplied under the Contract shall be delivered duty paid (DDP) under which risk is transferred to the buyer after having been delivered, hence insurance coverage is sellers' responsibility. Since the Insurance is seller's responsibility they may arrange appropriate coverage.

8. Warranty (GCC Clause 14)

GCC 14.2—In partial modification of the provisions, the warranty period shall be twelve (12) months or standard warranty period of the manufacturer or as per the extended warranty period from the date of acceptance of the Goods. The Supplier shall, in addition, comply with the performance and/or consumption guarantees specified under the Contract. During warranty/contract period, preventative maintenance, Installation qualification, operational qualification, QA/QC must be done as per manufactures checklist and guideline by trained personal. Response time during warranty and contract period would be 4 hours of less, and resolution time should not increase 7 days for any instance.

9. Payment (GCC Clause 15)

GCC 15.1—The method and conditions of payment to be made to the Supplier under this Contract shall be as follows:

- (a) Payment shall be made in Pak Rupees.
- (b) 100% of the Contract Price on complete delivery of store within ninety (90) days on submission of claim supported by acceptance certificate from procuring agency declaring Goods have been delivered and that all contracted services have been performed.
- (c) Part payment on part supply may be allowed

10. Prices (GCC Clause 16)

GCC 16.1— No price adjustment shall be permissible except in the event of changes in statutory taxes, duties, or exemptions under the applicable laws.

11. Liquidated Damages (GCC Clause 22)

GCC 22.1—In case deliveries are not completed within the time frame specified in the schedule of requirements / contract award, a Show Cause Notice will be served on the Bidder which will be following by cancellation of the Contract to the extent of non-delivered portion of installments. No supplies will be accepted and the amount of Performance Guarantee / Security to the extent of non-delivered portion of supplies of relevant installments will be forfeited. If the firm fails to supply the whole installments, maintenance the entire amount of Performance Guarantee/Security will be forfeited and the firm will be blacklisted at least for two years for future participation in bids:

The liquidated damage shall be 0.5 % per week or part thereof. The maximum amount of liquidated damages shall be 10% of the amount of contract. Once the cumulative amount of liquidated damages reaches ten percent (10%) of the amount of the contract, the Procuring Agency shall rescind the contract, without prejudice to other courses of action and remedies open to it.

12. Resolution of Disputes (GCC Clause 27)

GCC 27.1—The dispute resolution mechanism to be applied pursuant to GCC Clause 28.2 shall be as follows:

In the case of a dispute between the Procuring agency and the Supplier, the dispute shall be referred to the dispute resolution mechanism as defined in rule 31, 32 and 34 of the SPP Rules, 2010 (Amended).

13. Governing Language (GCC Clause 28)

GCC 28.1—The Governing Language shall be ENGLISH

14. Applicable Law (GCC Clause 29)

GCC 29.1-The Contract shall be interpreted in accordance with the laws of Islamic Republic of Pakistan which includes the following legislation:

The Employment of Children (ECA) Act 1991

The Bonded Labour System (Abolition) Act of 1992

The Factories Act 1934

15. Notices (GCC Clause 30)

GCC 30.1—**Procuring agency's address for notice purposes:**

Procurement Directorate at Central Warehouse,
Dow University of Health Sciences
(Ojha Campus), SUPARCO Road,
off Main University Road, Gulzar-e-Hijri,
Scheme No. 33, Karachi.
Phone No. + 92-21-99261497
Email: director.procurement@duhs.edu.pk

Supplier's address for notice purposes:

Name of Bidder: _____

Name of Contact Person & Designation: _____

Phone No. _____

Fax No. _____

Mobile Phone No. _____

Email Address _____

Part Two - Section IV
Schedule of Requirements

Schedule of Requirements

S#	Description of Goods	Qty.	Required Delivery Schedule	Location
01.	As per the details of items attached in Section V – Technical Specifications		Delivery & Installation within 60 Days or earlier from the date of Contact Award.	Ojha Campus of Dow University of Health Sciences, Karachi.

Part Two - Section V
Technical Specifications

Technical Specifications

PROJECT: DUHS SEMINAR HALL KARACHI (GROUP -A)

2% Earnest Money of Group-A: Rs. 937,320/-

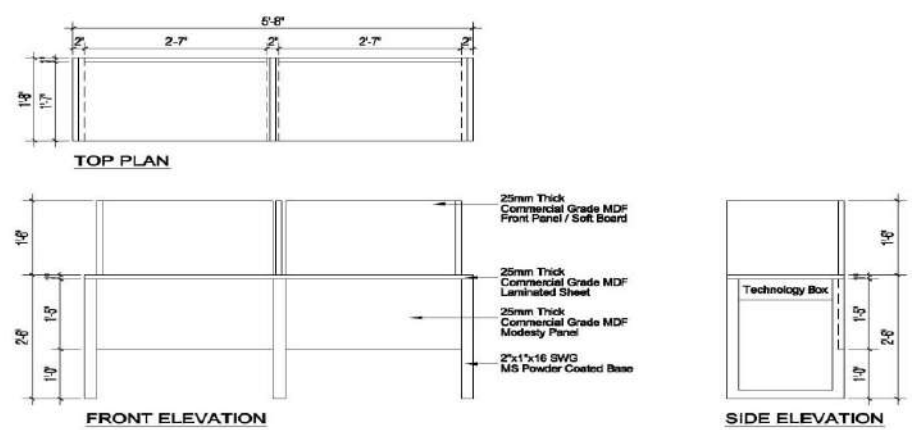
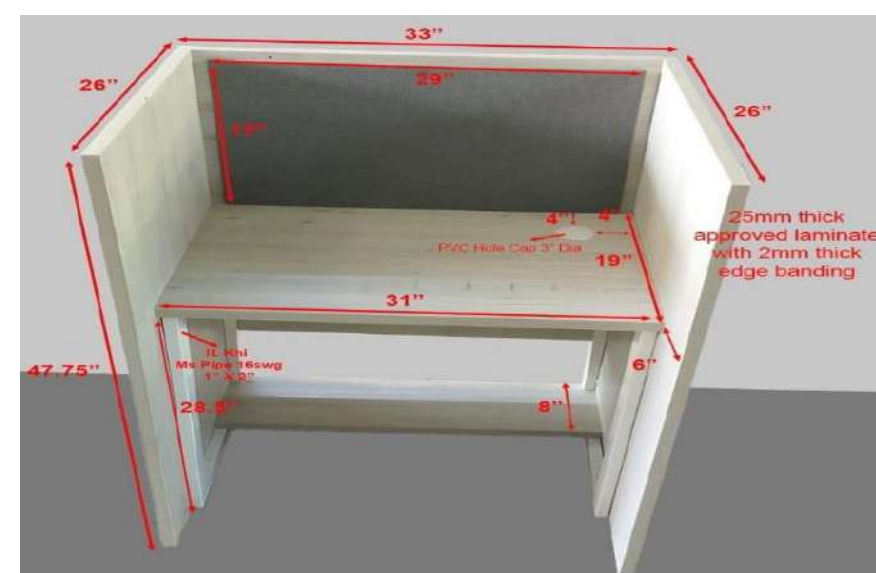
SERIAL	ITEM DESCRIPTION	UNIT	QTY	ITEM IMAGES
A-1	MODULAR WORKSTATION SET OF 2			
	<p>Providing and placing of Modular type workstation with the following features;</p> <p>Table Top: Made of High quality commercial Grade board MDF with 25mm thick imported laminate / tactile finish color code 4089 sheet pressed on top surface with PVC edge banding (2mm thick) on all sides with two cable grommets for wire management per unit.</p> <p>Frame/Base: Durable Powder-coated 16 gauge MS rectangular tube frame finished in white powder coating. Open-frame rectangular loop design with Integrated black modesty panel under table top for structural support.</p> <p>Front Panel: Soft board made of MDF sheet fabric finish. Thickness 18mm. Fixed with metal brackets / clamps.</p> <p>Additional Features: Structure Knockdown type for easy transport and assembly. (modern, professional aesthetic)</p> <p>Technology Box: Made of MS powder coated sheet with fire radiant internal housing, 04 × Universal power sockets (compatible with local plug types) Rated: 220–240V AC, 50Hz, With internal wiring and terminal block, 04 × RJ45 Data ports (Cat6)</p> <p>Notes: Product warranty must be 05 years. Rates shall include all necessary accessories and fittings for complete installation.</p> <p>Dimensions: L- 5'-8" X W- 2'-0" X H- 2'-6"</p>	Each	312	 <p style="text-align: center;">Shop Drawing Modular Workstation</p> 

Providing and placing of Seminar Hall Officer Table complete with the following features,
Tabletop: Made of High-quality commercial Grade board MDF with 25mm thick imported laminate / Tactile finish color code 4089 pressed on top surface with PVC edge banding (2mm thick) on all sides and cable management grommet or flip cover for wire access.

Frame/Base: Durable Powder-coated 16-gauge MS rectangular tube frame finished in White powder coating. Open-frame rectangular loop design with modesty panel under tabletop finished in 25mm thick same specification as tabletop also to support the structure.

Drawer Pedestal: Made with same specification as table with 3-drawer fixed pedestal (top drawer with lock). Handles Aluminum or stainless-steel pull handles. Slides Smooth ball-bearing or roller slide mechanism.

Additional Features: Structure Knockdown type for easy transport and assembly. (modern, professional aesthetic)

Notes: Product warranty must be 05 years. Rates shall include all necessary accessories and fittings for complete installation.

Table Dimensions: L- 4'-7" X W- 2'-3" X H- 2'-6"

Drawer Pedestal Dimensions: D- 2'-0" X W- 1'-6" X H- 2'-6"

Each

14

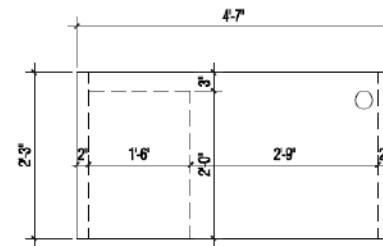

TOP PLAN

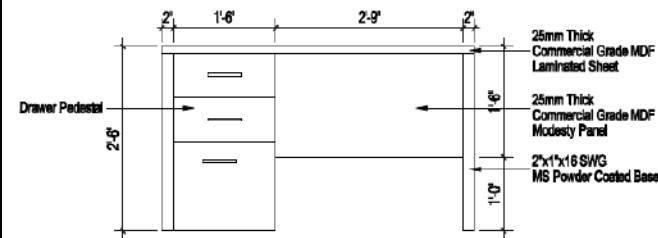

FRONT ELEVATION

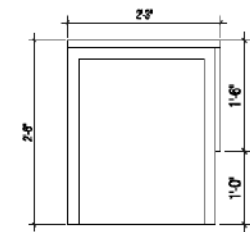

SIDE ELEVATION

Shop Drawing Seminar Hall Table



Providing and placing of Officer Table & Side rack complete with the following features;

Table Top: Made of High quality commercial Grade board MDF with 25mm thick imported laminated sheet pressed on top surface with PVC edge banding (2mm thick) on all sides and Central cable management grommet or flip cover for wire access Finished in Scratch-resistant and heat-resistant laminate surface.

Frame/Base: Durable Powder-coated 16 guage MS rectangular tube frame finished in Matte black powder coating. Open-frame rectangular loop design with modesty panel 25mm laminated board matching Same as table top for aesthetic uniformity and also for structural support.

Side Rack: Finished in Same laminated board, 1 swing door cabinet with internal shelf. 1–2 drawers depending on customization. Handles finished in brushed stainless steel or aluminum. Locking Mechanism optional lock can be added for the cabinet unit.

Additional Features: Structure Knockdown type for easy transport and assembly.

Notes: Product warranty must be 05 years. Rates shall include all necessary accessories and fittings for complete installation.

Table Dimensions: L- 5'-0" X W- 2'-6" X H- 2'-6". **Side Rack Dimensions:** L- 3'-0" X W- 1'-6" X H- 2'-0"

Each

2



A-4

REST ROOM AREA TABLES

Providing and placing Rest room area tables complete with the following features;
Tabletop: Made of High-quality commercial Grade board MDF with 25mm thick imported laminated sheet pressed on top surface with PVC edge banding (2mm thick) on all sides.
Frame/Base: Durable Powder-coated 16-gauge MS rectangular tube frame finished in White powder coating. Open-frame rectangular loop design, side modesty panel 18mm MDF laminated board finished same as tabletop. Left side closed panel with integrated footrest shelf modesty panel for front privacy. One open shelf below the worktop on the left-hand side for document or bag storage.
Additional Features: Structure Knockdown type for easy transport and assembly.
Notes: Product warranty must be 05 years. Rates shall include all necessary accessories and fittings for complete installation.
Dimensions: L- 4'-7" X W- 2'-3" X H- 2'-6"

Each

4



A-5	SIDE TABLE			
	<p>Supply and installation of side table constructed using high-quality commercial-grade board MDF with an 18mm thick imported laminate / Tactile finish color code 4089 sheet pressed on the top surface, complete with matching edge lipping. The base shall be fabricated from a durable 16 guage MS frame. All exposed surfaces are to be finished with a premium powder-coated polish. The quoted rates shall include the cost of all necessary accessories, fittings, and finishing works, including polishing where required.</p> <p>Notes: Final selection of laminate color to be approved by the Architect upon physical inspection of swatches. Product warranty must be 05 years.</p> <p>Rates shall include all necessary accessories, hardware, and components for full installation and functionality.</p> <p>Dimensions: W- 1'-6" x D- 1'-6" X H- 1'-6"</p>	Each	4	

Providing and placing of Linear type workstation complete with the following features;

Tabletop: Made of High-quality commercial Grade board MDF with 25mm thick imported laminate / Tactile finish color code 4089 sheet pressed on top surface with PVC edge banding (2mm thick) on all sides with cable grommets for wire management and Mobile pedestal drawer unit Width: 14 inches. Premium quality central locking system includes 3 master keys.

Frame/Base: Durable Powder-coated 16-gauge MS A-shaped inclined fork feet finished in Matte white powder coating. Integrated modesty panel under tabletop for structural support.

Front Panel: Soft board made of MDF sheet fabric finish. Thickness 18mm. Fixed with metal brackets / clamps.

Additional Features: Structure Knockdown type for easy transport and assembly. Color Scheme White top with black frame and dividers (modern, professional aesthetic)

Notes: Product warranty must be 05 years. Rates shall include all necessary accessories and fittings for complete installation.

Dimensions: L- 4'-10" X W- 2'-6" X H- 2'-6"

Each

4



A-7	SINGLE BED			
	<p>Supply, fabrication, and installation of typical customized single bed for with the following features,</p> <p>Finish: Red oak wood. Stain-resistant PU polish finish. Smoothened corners for safety. Termite and borer resistant wood</p> <p>Center Support: 78" long × 4" wide × 1-1/2" thick, constructed from Partal wood and secured manually using wooden U-fittings</p> <p>Mattress: 6 inches best quality mattress.</p> <p>Headboard & Footboard: Solid panel design with wooden framing.</p> <p>Storage: Pull-out drawers on one side. Same wood finish or high-grade plywood with channels. Handle Type: Groove handle or knob</p> <p>Notes: Product warranty must be 05 years. Rates shall include all necessary accessories and fittings for complete installation.</p> <p>Dimensions: 36" wide × 84" long × 48" high (headboard) × 18" high (footboard).</p>	Each	8	

A-8	SINGLE BED SIDE TABLE			
	<p>Supply, fabrication, and installation of typical customized single bedside table for with the following features.</p> <p>Finish: Red oak wood. Stain-resistant PU polish finish. Smoothened corners for safety. Termite and borer resistant wood</p> <p>Storage: 2 Small drawers (top row) 1 Large drawer (bottom full-width) with Wooden square knobs</p> <p>Notes: Product warranty must be 05 years. Rates shall include all necessary accessories and fittings for complete installation.</p> <p>Dimensions: H- 1-6" X W- 1-6" X D- 1-6"</p>	Each	8	

A-9

RECEPTION COUNTER

Supply, fabrication, and installation of customized Reception Counter for with the following features;
Counter Structure: Internal frame made of seasoned hardwood, Properly anchored to floor, Internal framing designed to carry solid surface load.
Counter Top: Countertop made of Corian (Dupont)
Decorative vertical recessed panels: Panel with dark wood grain laminate with 18mm thickness
External Finish 12mm thick solid surface high gloss sheet, Thermoformed seamless joints, Scratch, stain, and chemical resistant, All edges machine-rounded. **Skirting:** Stainless steel strip 2" High
Storage: 4 No Drawer units with soft-close channels, Lockable shutter cabinets.
Notes: Product warranty must be 05 years. Rates shall include all necessary accessories and fittings for complete installation.
Dimensions: L- 21'-0" X D- 2'-8" X Working Height 2'-0" X Counter Height 4'-0"

Each

2





PROJECT: DUHS SEMINAR HALL KARACHI (GROUP -B)

2% Earnest Money of Group-B: Rs. 2,000,919/-

SERIAL	ITEM DESCRIPTION	UNIT	QTY	ITEM IMAGES
B-1	SEMINAR LOW BACK CHAIR			
	<p>Providing and placing of Low-back revolving chair complete with the following features;</p> <p>Made: Master Offisys / Chairister or equivalent standard</p> <p>Design: Low Back revolving chair fabric finished.</p> <p>Structure: Fabric / Leatherite integrated with Moulded Foam over One Piece 3-D Bended Ply Shells for seat and back,</p> <p>Armrests: Fixed / Height-adjustable armrests to suit user preference and ergonomic requirements.</p> <p>Mechanism: Non Lockable, Non tilting / Non-reclining mechanism with single-locking function and Class-3 gas lift for smooth height adjustment.</p> <p>Base: Sturdy black nylon 5-star base fitted with reinforced PU coated GLIDES.</p> <p>Functionality: Multi-functional mechanism with automatic self-weight adjustment for personalized support.</p> <p>Notes: Final selection of fabric finishes to be approved upon physical inspection of swatches by the Architect. Product warranty must be 03 years. Quoted rates include all necessary accessories and components required for complete assembly and functionality.</p>	Each	624	

B-2	OFFICE STAFF HIGH BACK CHAIR			
	<p>Providing and placing of Medium-back revolving chair, complete with the following features;</p> <p>Made: Master Offisys or Chairister.</p> <p>Design: Ergonomic Medium-back revolving chair Leatheritte Finish.</p> <p>Frame: Top leatherite integrated with MOULDED FOAMove single piece 3D bended ply shells with lumbar support for enhanced comfort.</p> <p>Armrests: Leatherite Padding soft armrest Fixed / Height-adjustable to suit user preference and ergonomic requirements.</p> <p>Mechanism: Synchronized / tilting mechanism with single-locking function and Class-3 gas lift for smooth height adjustment. BIFMA approved.</p> <p>Base: Nylon 5-star base fitted with reinforced PU castors for mobility and stability.</p> <p>Functionality: Multi-functional mechanism with automatic self-weight adjustment for personalized support.</p> <p>Notes: Final selection of Leatherite and fabric finishes to be approved upon physical inspection of swatches by the Architect. Product warranty must be 05 years.</p> <p>Inclusions: Quoted rates to include all necessary accessories and components required for complete assembly and functionality.</p>	Each	32	

B-3	VISITOR CHAIR FIXED BASE			
	<p>Providing and placing of visitor chair with the following specifications: Made: Master Offisys or Chairister. Base: Fixed base structure for stable and non-revolving seating. Design: Ergonomic design with comfortable Leatheritte finish. Frame: Durable metal frame with powder-coated or chrome-plated finish (as approved) Seat and Back: Upholstered with high-density foam and fabric or Leatherite (as per final approved swatch) Armrests: Integrated or fixed armrests Notes: Final finish and upholstery shall be approved by the Architect upon physical inspection of swatches. Product warranty must be 03 years. Rates shall include all necessary accessories and fittings for complete installation.</p>	Each	32	

B-4	SEMINAR CHAIR WITH FIXED BASE			
	<p>Providing and placing of Seminar chair with the following specifications: Made: Master Offisys or Chairister. Base: Fixed base structure for stable and non-revolving seating & Fitted with durable plastic glides to protect flooring and ensure ease of movement. Design: Ergonomic design with comfortable fabric finish. Frame: Durable metal frame with powder-coated or chrome-plated finish (as approved) Seat and Back: Upholstered with high-density foam and fabric or Leathjerite (as per final approved swatch) Features: Writing board with pen slot. Notes: Final finish and upholstery shall be approved by the Architect upon physical inspection of swatches. Product warranty must be 03 years. Rates shall include all necessary accessories and fittings for complete installation.</p>	Each	1757	

B-5	SINGLE SEAT SOFA			
	<p>Providing and supplying Single Seat Sofa with solid wood and particle board frame, constructed as per the following specifications:</p> <p>Frame: Combination of solid wood and particle board for structural durability.</p> <p>Seat: High-density foam upholstered with premium leatherette or fabric, as per final approval.</p> <p>Base: Fitted with durable plastic glides to protect flooring and ensure ease of movement.</p> <p>Support: Integrated imported spring mechanism for enhanced strength and long-term seating comfort.</p> <p>Notes: Final selection of fabric, faux leatherette, and color to be approved by the Architect upon physical inspection of swatches. Product warranty must be 03 years.</p> <p>Rates shall include all necessary accessories, hardware, and components for full installation and functionality.</p>	Each	8	

SPECIAL NOTE

1. The bidder must submit samples before the opening of the tender to DUHS. Alternatively, the bidder may provide a reference list of previously delivered quoted products to DUHS to facilitate the technical evaluation and quality assessment of the offered products.
2. **A sample or partial sample of the item will be approved prior to the final production.**
3. DUHS may reject the bid/or part of it if previous experience in terms of supplies and service is not satisfactory.
4. All parts/accessories must be included for complete operation, and all optional parts must be quoted in the bid, if not quoted, it will be considered Free of cost.

Part Two - Section VI
Sample Forms

A. Bid Form and Price Schedules

NIT / IFB N°: _____

Date: _____

To: *[name and address of Procuring Agency]*

Gentlemen and/or Ladies:

Having examined the bidding documents including Addenda Nos. ***[insert numbers]***, the receipt of which is hereby duly acknowledged, we, the undersigned, offer to supply and deliver ***[description of goods and services]*** in conformity with the said bidding documents for the sum of ***[total bid amount in words and figures]*** or such other sums as may be ascertained in accordance with the Schedule of Prices attached herewith and made part of this Bid.

We undertake, if our Bid is accepted, to deliver the goods ***[insert offered delivery schedule]***.

If our Bid is accepted, we will obtain the guarantee of a bank in a sum equivalent to _____ percent of the Contract Price for the due performance of the Contract, in the form prescribed by the Procuring agency.

We agree to abide by this Bid for a period of ***[number]*** days from the date fixed for Bid opening under Clause 22 of the Instructions to Bidders, and it shall remain binding upon us and may be accepted at any time before the expiration of that period.

Until a formal Contract is prepared and executed, this Bid, together with your written acceptance thereof and your notification of award, shall constitute a binding Contract between us.

Commissions or gratuities, if any, paid or to be paid by us to agents relating to this Bid, and to contract execution if we are awarded the contract, are listed below:

Name and address of agent	Amount and Currency	Purpose of Commission or gratuity
_____	_____	_____
_____	_____	_____
_____	_____	_____

(if none, state "none")

We understand that you are not bound to accept the lowest or any bid you may receive.

Dated this _____ day of _____ 20_____.

[Signature]

[in the capacity of]

Duly authorized to sign Bid for and on behalf of _____

**(A) PRICE SCHEDULE IN PAK RUPEES
Delivered Duty Paid (DDP BASIS - EXCLUDING GST)**

FOR GOODS OFFERED WITHIN THE PROCURING AGENCY'S COUNTRY

Name of Bidder _____ . IFB / NIT Number _____ .

S#	Detailed Specification of Goods	Model / Cat No.	Name of Manufacturer	Country of Origin	Quantity of Stores	Unit	Rate Per Unit (Excluding GST)	Total Price (Excluding GST)
1	2	3	4	5	6	7	8	9
Total Amount in Pak Rs. on DDP Basis (Excluding GST)								

Name _____

In the capacity of _____

Signed _____

Duly authorized to sign the Bid for and on behalf of _____

Date _____

B. Bid Security Form

Whereas *[name of the Bidder]* (hereinafter called "the Bidder") has submitted its bid dated *[date of submission of bid]* for the supply of *[name and/or description of the goods]* (hereinafter called "the Bid").

KNOW ALL PEOPLE by these presents that WE *[name of bank]* of *[name of country]*, having our registered office at *[address of bank]* (hereinafter called "the Bank"), are bound unto *[name of Procuring agency]* (hereinafter called "the Procuring agency") in the sum of for which payment well and truly to be made to the said Procuring agency, the Bank binds itself, its successors, and assigns by these presents. Sealed with the Common Seal of the said Bank this ___ day of __20__.

THE CONDITIONS of this obligation are:

1. If the Bidder withdraws its Bid during the period of bid validity specified by the Bidder on the Bid Form; or
2. If the Bidder, having been notified of the acceptance of its Bid by the Procuring agency during the period of bid validity:
 - a. fails or refuses to execute the Contract Form, if required; or
 - b. fails or refuses to furnish the performance security, in accordance with the Instructions to Bidders;

we undertake to pay to the Procuring agency up to the above amount upon receipt of its first written demand, without the Procuring agency having to substantiate its demand, provided that in its demand the Procuring agency will note that the amount claimed by it is due to it, owing to the occurrence of one or both of the two conditions, specifying the occurred condition or conditions.

This guarantee will remain in force up to and including twenty eight (28) days after the period of bid validity, and any demand in respect thereof should reach the Bank not later than the above date.

[signature & Seal of the bank]

C. Contract Form

THIS AGREEMENT made the _____ day of _____ 20 _____ between [name of Procuring Agency] (hereinafter called "the Procuring Agency") of the one part and [name of Supplier] of [city and country of Supplier] (hereinafter called "the Supplier" of the other part:

WHEREAS the Procuring agency invited bids for certain goods and ancillary services, viz., *[brief description of goods and services]* and has accepted a bid by the Supplier for the supply of those goods and services in the sum of *[contract price in words and figures]* (hereinafter called "the Contract Price").

NOW THIS AGREEMENT WITNESSETH AS FOLLOWS:

1. In this Agreement words and expressions shall have the same meanings as are respectively assigned to them in the Conditions of Contract referred to.
2. The following documents shall be deemed to form and be read and construed as part of this Agreement, viz.:
 - a) the Bid Form and the Price Schedule submitted by the Bidder;
 - b) the Schedule of Requirements;
 - c) the Technical Specifications;
 - d) the General Conditions of Contract;
 - e) the Special Conditions of Contract; and
 - f) the Procuring agency's Notification of Award.
3. In consideration of the payments to be made by the Procuring agency to the Supplier as hereinafter mentioned, the Supplier hereby covenants with the Procuring agency to provide the goods and services and to remedy defects therein in conformity in all respects with the provisions of the Contract
4. The Procuring agency hereby covenants to pay the Supplier in consideration of the provision of the goods and services and the remedying of defects therein, the Contract Price or such other sum as may become payable under the provisions of the contract at the times and in the manner prescribed by the contract.

IN WITNESS whereof the parties hereto have caused this Agreement to be executed in accordance with their respective laws the day and year first above written.

Signed, sealed, delivered by _____ the (for the Procuring agency)

Signed, sealed, delivered by _____ the (for the Supplier)

D. Performance Security Form

To: *[name of Procuring agency]*

WHEREAS *[name of Supplier]* (hereinafter called "the Supplier") has undertaken, in pursuance of Contract No. *[reference number of the contract]* dated _____ 20. to supply *[description of goods and services]* (hereinafter called "the Contract").

AND WHEREAS it has been stipulated by you in the said Contract that the Supplier shall furnish you with a bank guarantee by a reputable bank for the sum specified therein as security for compliance with the Supplier's performance obligations in accordance with the Contract.

AND WHEREAS we have agreed to give the Supplier a guarantee:

THEREFORE WE hereby affirm that we are Guarantors and responsible to you, on behalf of the Supplier, up to a total of *[amount of the guarantee in words and figures]*, and we undertake to pay you, upon your first written demand declaring the Supplier to be in default under the Contract and without cavil or argument, any sum or sums within the limits of *[amount of guarantee]* as aforesaid, without your needing to prove or to show grounds or reasons for your demand or the sum specified therein.

This guarantee is valid until the _____ day of 20._____.

Signature and seal of the Guarantors

[name of bank or financial institution]

[address]

[date]

E. Bank Guarantee for Advance Payment

To: *[name of Procuring agency]*

[name of Contract]

Gentlemen and/or Ladies:

In accordance with the payment provision included in the Special Conditions of Contract, which amends Clause 16 of the General Conditions of Contract to provide for advance payment, *[name and address of Supplier]* (hereinafter called "the Supplier") shall deposit with the Procuring agency a bank guarantee to guarantee its proper and faithful performance under the said Clause of the Contract in an amount of *[amount of guarantee in figures and words]*.

We, the *[bank or financial institution]*, as instructed by the Supplier, agree unconditionally and irrevocably to guarantee as primary obligator and not as surety merely, the payment to the Procuring agency on its first demand without whatsoever right of objection on our part and without its first claim to the Supplier, in the amount not exceeding *[amount of guarantee in figures and words]*.

We further agree that no change or addition to or other modification of the terms of the Contract to be performed thereunder or of any of the Contract documents which may be made between the Procuring agency and the Supplier, shall in any way release us from any liability under this guarantee, and we hereby waive notice of any such change, addition, or modification.

This guarantee shall remain valid and in full effect from the date of the advance payment received by the Supplier under the Contract until *[date]*.

Yours truly,

Signature and seal of the Guarantors

[name of bank or financial institution]

[address]

[date]

F. Manufacturer's Authorization Form

[See Clause 13.3 (a) of the Instructions to Bidders.]

To:
The [Procuring Agency]
Karachi.

WHEREAS [name of the Manufacturer] who are established and reputable manufacturers of [name and/or description of the goods] having factories at [address of factory] do hereby authorize [name and address of Agent] to submit a bid, and subsequently negotiate and sign the Contract with you against IFB No. [reference of the Invitation to Bid] for the above goods manufactured by us.

We hereby extend our full guarantee and warranty as per Clause 15 of the General Conditions of Contract for the goods offered for supply by the above firm against this Invitation for Bids.

We hereby undertake that we will provide the complete after sale services support in case of agency transfer or withdrawn from the bidder and will inform timely of any transition.

Our representative may be reached in need of support,

Name:

Designation:

Email Address:

[signature for and on behalf of Manufacturer]

Note: This letter of authority should be on the letterhead of the Manufacturer and should be signed by a person competent and having the power of attorney to bind the Manufacturer. It should be included by the Bidder in its bid.

G. Integrity Pact (AFFIDAVIT)

DECLARATION OF FEES, COMMISSION AND BROKERAGE ETC. PAYABLE BY THE SUPPLIERS/CONTRACTORS/CONSULTANTS.

Contract Number: _____ Dated: _____
Contract Value: _____
Contract Title: _____

[Name of Supplier/Contractor/Consultant] hereby declares that it has not obtained or induced the procurement of any contract, right, interest, privilege or other obligation or benefit from Government of Sindh (GoS) or any administrative subdivision or agency thereof or any other entity owned or controlled by it (GoS) through any corrupt business practice.

Without limiting the generality of the foregoing, **[Name of Supplier/ Contractor/ Consultant]** represents and warrants that it has fully declared the brokerage, commission, fees etc. paid or payable to anyone and not given or agreed to give and shall not give or agree to give to anyone within or outside Pakistan either directly or indirectly through any natural or juridical person, including its affiliate, agent, associate, broker, consultant, director, promoter, shareholder, sponsor or subsidiary, any commission, gratification, bribe, finder's fee or kickback, whether described as consultation fee or otherwise, with the object of obtaining or inducing the procurement of a contract, right, interest, privilege or other obligation or benefit, in whatsoever form, from Procuring Agency (PA), except that which has been expressly declared pursuant hereto.

[Name of Supplier/Contractor/Consultant] certifies that it has made and will make full disclosure of all agreements and arrangements with all persons in respect of or related to the transaction with PA and has not taken any action or will not take any action to circumvent the above declaration, representation or warranty.

[Name of Supplier/Contractor/Consultant] accepts full responsibility and strict liability for making any false declaration, not making full disclosure, misrepresenting facts or taking any action likely to defeat the purpose of this declaration, representation and warranty. It agrees that any contract, right, interest, privilege or other obligation or benefit obtained or procured as aforesaid shall, without prejudice to any other right and remedies available to PA under any law, contract or other instrument, be voidable at the option of PA.

Notwithstanding any rights and remedies exercised by PA in this regard, **[Name of Supplier/Contractor/Consultant]** agrees to indemnify PA for any loss or damage incurred by it on account of its corrupt business practices and further pay compensation to PA in an amount equivalent to ten times the sum of any commission, gratification, bribe, finder's fee or kickback given by **[Name of Supplier/Contractor/Consultant]** as aforesaid for the purpose of obtaining or inducing the procurement of any contract, right, interest, privilege or other obligation or benefit, in whatsoever form, from PA.

[Procuring Agency]

[Supplier /Contractor/Consultant]

Sample Forms

(FORM - C)

FINANCIAL EVALUATION SHEET

Year	Annual Turnover for the last 3 years Year (PKR)
Year 1	
Year 2	
Year 3	
TOTAL	
Average Turn-over in 3 years	

Financial Information in PKR	Year 1	Year 2	Year 3
Total Assets (TA)			
Total Liabilities (TL)			
Current Assets (CA)			
Current Liabilities (CL)			
Total / Gross Revenue (TR)			

Supporting Document		Yes / No
Income Tax Returns	Year 1	
	Year 2	
	Year 3	

DAWN

E-PAPER | MAY 25, 2026



DOW UNIVERSITY OF HEALTH SCIENCES

No. DUHS/DP/2026/343-344

Dated 13 May 2026

NOTICE INVITING TENDER (NIT)

Dow University of Health Sciences, Karachi (DUHS) invites e-bids through E-Pak Acquisition and Disposal System (EPADS) from the manufacturers or their authorized agents/distributors/firms. Bidders must be registered and appear on the 'List of Active Taxpayers' of FBR/SRB for income tax and GST/SST (whichever is applicable) for the supply of following categories/items/goods and Ancillary Services at Dow University of Health Sciences, Karachi". Bidding Documents containing detailed Terms and Conditions can be viewed/downloaded from <https://portalsindh.eprocure.gov.pk/#/> OR <https://duhs.edu.pk>.

Electronic bids should be submitted through EPADS only. Manual bids will not be received/entertained. Interested bidders are required to register themselves on the EPAD System at the link <https://sindh.eprocure.gov.pk/#/supplier/registration> for submission of electronic bids.

The bids, prepared according to the instructions provided in the bidding documents, must be submitted on EPADS by **16th June, 2026 at 1100 Hrs.** The original instrument of the **tender fee of Rs. 2,000/- (Non-refundable) and bid security not less than mentioned percent (%) of the estimated value of the tender OR item/group** as per following details must be reach the procuring agency (Procurement Directorate at Central Warehouse, Dow University of Health Sciences (Ojha Campus), SUPARCO Road, off Main University Road, Gulzar-e-Hijri, Scheme No. 33, Karachi) before the deadline for submission of e-bids, which will be opened on the same day at **1130 Hrs.**

S#	Category	Tender Reference Number	Amount of Bid Security
1.	Procurement of Papers, Stationary, General & IT Consumable, Printing Material, IT Hardware & Network Items. DDP Basis (Excluding GST) Single Stage - One Envelope Procedure under Rule 46(1) of SPP Rules 2010, on rate contract basis.	DUHS/ DP/2026/ 343	Amount indicated against each item in Section V of Bidding Documents (2% of Estimated Cost)
2.	Procurement of Furniture/ Fixtures for Construction of Seminar Hall DDP Basis (Excluding GST) Single Stage - One Envelope Procedure under Rule 46(1) of SPP Rules 2010.	DUHS/ DP/2026/ 344	Amount indicated against each group in Section V of Bidding Documents (2% of Estimated Cost)

Note:

- For any query regarding e-bidding, please contact the Director Procurement Office at Tel: 021-38771111 (Ext. 4433)
- In case Govt. announces any public holiday or any unfavorable circumstances the tender/bids will be submitted and opened on the next working day, at the same venue and time.
- The purchaser reserves the right to reject any/all bids under the relevant provisions of SPP Rules 2010 (Amended).
- In case of any difficulty, prospective bidders may contact the EPADS Helpline 051-111-137-237 during working days/hours.

Director Procurement
Dow University of Health Sciences, Karachi

www.duhs.edu.pk
Bibi-e-Linda Road, Karachi - 74200 Pakistan.
Tel: 021-38771111 Fax: 021-59216465

www.jang.com.pk
 JangDotComDotPk jangdotcom jang_akhbar
 پاکستان کے روزنامہ گراہی
 ABC
 یقیناً تصدیق شدہ اشاعت
 THE DAILY JANG KARACHI
 جنگ
 بقی سید علیل الرحمن
 90
 پیر 8 ذوالحجہ 1447ھ 25 مئی 2026ء

MONDAY MAY 25, 2026



DOW UNIVERSITY OF HEALTH SCIENCES

تاریخ: 13 مئی 2026 DUHS/DP/2026/343-344 آئی ایف بی نمبر

بولیوں میں مطلوب ہیں

ڈاؤ یو نیورٹی آف ہیلتھ سائنسز (ڈی یو ایچ ایس) کراچی کو ای پاک اکیڈمی زینٹن اینڈ اسپڈز ایل سی (EPADS) کے ذریعے مینوفیکچررز اور ان کے مہازا کیٹس اور سٹری بیٹرز سے ای بولیوں میں مطلوب ہیں۔

اہل بولی دہندگان ڈاؤ یو نیورٹی آف ہیلتھ سائنسز کراچی میں متعدد ذیل مختلف کنٹیکٹرز یا آن لائن آرمان اور مہلات سرورسز فراہمی کیلئے فیڈرل بورڈ آف ریجسٹرڈ (FBR) اسٹندہ ریجسٹرڈ بورڈ میں ریکارڈس اور ای ایس ٹی ایس ٹی ایس ٹی (جیسا کہ قابل اطلاق) کیلئے ایکٹیو لیٹس کنٹریکٹس میں شامل ہوں۔ تفصیلی شرائط و شواہد پر مشتمل بولی کی دستاویزات

https://portal.sindh.eprocure.gov.pk/#/ اور https://duhs.edu.pk پر دیکھی اور ڈاؤن لوڈ کی جا سکتی ہیں۔

ایکٹرا تک بولیوں میں صرف EPADS کے ذریعے ہی بولی جمع کرائی جا سکتی ہے۔ دستی بولیوں میں وصول نہیں کی جا سکتی گی۔ دلچسپی رکھنے والے بولی دہندگان کیلئے ایکٹرا تک بولی جمع کرائے کیلئے لنک (https://sindh.eprocure.gov.pk/#/supplier) registration کے ذریعے ای بیڈ سسٹم پر رجسٹر ہونا ضروری ہے۔

بولی دستاویزات میں دی گئیں ہدایات کے مطابق تیاری گئیں بولیوں EPADS پر 16 جون 2026 کو صبح 11:00 بجے تک جمع کرائی جا سکتی ہیں۔ اصل ٹینڈر فیس مبلغ 2,000 روپے (دو ہزار روپے) اور مندرجہ ذیل تفصیل کے مطابق بڈنگ بولی ٹینڈر یا آئٹم / گروپ کی حتمی قیمت کے طور پر فیصد (%) سے کم نہ ہو، لازماً پروکیورنگ ایجنسی کو پروکیورمنٹ ڈائریکٹریٹ سینٹرل ویکس ہاؤس، ڈاؤ یو نیورٹی آف ہیلتھ سائنسز (اوجھا کیمپس)، پارکو روڈ، جنرل ہسپتال میں ڈاؤ یو نیورٹی روڈ، بھنگرا بھنگری، اسکیم نمبر 33، کراچی کو ای بولی جمع کرائے کی مقررہ وقت سے پہلے پہنچ جانے کی ضروری روڈ وہاں پہنچنے کیلئے 11:30 بجے تک بولی جمع کرانے کی۔

S#	Category	Tender Reference Number	Amount of Bid Security
1.	Procurement of Papers, Stationary, General & IT Consumable, Printing Material, IT Hardware & Network Items. DDP Basis (Excluding GST) Single Stage - One Envelope Procedure under Rule 46(1) of SPP Rules 2010, on rate contract basis.	DUHS/DP/2026/343	Amount indicated against each item in Section V of Bidding Documents (2% of Estimated Cost)
2.	Procurement of Furniture/ Fixtures for Construction of Seminar Hall DDP Basis (Excluding GST) Single Stage - One Envelope Procedure under Rule 46(1) of SPP Rules 2010.	DUHS/DP/2026/344	Amount indicated against each group in Section V of Bidding Documents (2% of Estimated Cost)

نوٹ:

- ای بڈنگ کے حوالے سے کسی بھی سوال یا معلومات کیلئے ڈائریکٹریٹ پروکیورمنٹ آفس سے فون نمبر (Ext. 4433) 021-38771111 پر رابطہ کریں۔
- سروس کی جانب سے تشکیل یا ترمیمی صورت حال کے سبب ٹینڈر بولیوں اس کے اگلے ہی روز ای مقام اور وقت پر جمع کی جا سکتی ہیں اور کوئی جاسکتی گی۔
- غریب آرمان نی ٹی روڈ 2010 (ترمیم شدہ) کی محدود دفعات کے تحت کسی بھی ای مقام بولیوں کو مسترد کرنے کا حق محفوظ رکھتا ہے۔
- کسی بھی دشواری کی صورت میں بولی دہندگان ایم کار کے دوران EPADS ایپ ٹاؤن 051-111-137-237 پر رابطہ کر سکتے ہیں۔

www.duhs.edu.pk
 Main Office: Road No. 1, Phase II, DHA Karachi
 Tel: 371-6811, Fax: 371-9811

ڈائریکٹریٹ پروکیورمنٹ
 ڈاؤ یو نیورٹی آف ہیلتھ سائنسز، کراچی۔

ABC Certified The Largest Circulated Sindhi Daily of Pakistan

هڪ ئي وقت ڪراچي، حيدرآباد ۽ سکر مان شايع ٿيندڙ پهرين سنڌي اخبار

DAILY KAWISH روزانه

Monday, 25 May, 2026

(جلد 36) سومر 25 مئي 2026 ۽ بمطابق 08 ذوالحج 1447ھ (شمارو 293) قيمت 40 روپيا

DOW UNIVERSITY OF HEALTH SCIENCES

آءِ ايف بي نمبر: DUHS/DP/2026/343-344 تاريخ: 13 مئي 2026

واڪ گهريل آهن

ڊاٽو يونيورسٽي آف هيلٿ سائنسز (ڊي يو اِيڇ ايس) ڪراچي کي اِي پاڪ ايڪيوزيشن اينڊ ڊسپوزيل سسٽم (EPADS) جي ذريعي مينوفڪچررز/انهن جي مجاز ايجنٽس/ڊسٽريبيوٽرز کان اِي واڪ گهريل آهن.

اهل واڪ ڏيندڙ ڊاٽو يونيورسٽي آف هيلٿ سائنسز ڪراچي پر هيٺ ڄاڻايل مختلف ڪيٽيگريز/ آئٽمز/ سامان ۽ لاڳاپيل سروسز جي فراهمي لاءِ فيڊرل بورڊ آف روينيو (FBR) ۽/يا سنڌ روينيو بورڊ پر انڪم ٽيڪس ۽ جي ايس ٽي/ايس ايس ٽي (جيٽن ٽي لاڳو ٿيڻ جو چوڳو) لاءِ ايڪٽيو ٽيڪس پيئر فهرست ۾ شامل هجن. تفصيلي شرطن ۽ ضابطن تي مشتمل واڪ دستاويز

<https://duhs.edu.pk/#/> يا <https://portalsindh.eprocure.gov.pk/#/> تي ڏسي/ڊائون لوڊ ڪري سگهجن ٿا.

اليڪٽرانڪ واڪ صرف EPADS ذريعي جمع ڪرايا وڃن. هٿوٿ واڪ وصول نه ڪيا ويندا. دلچسپي رکندڙ واڪ ڏيندڙن لاءِ اليڪٽرانڪ واڪ جمع ڪرائڻ لاءِ لنڪ:

<https://sindh.eprocure.gov.pk/#/supplier/registration> جي ذريعي اِي پيڊ سسٽم تي رجسٽر هئڻ ضروري آهي.

واڪ دستاويزن ۾ ڏنل هدايتن مطابق تيار ڪيل واڪ EPADS تي 16 جون 2026 تي صبح 11:00 وڳي تائين جمع ڪرايا وڃن. اصل ٽينڊر في 2000 روپيا (ناقابل واپسي) ۽ هيٺ ڏنل تفصيل مطابق ٻڌ سيڪيورٽي ٽينڊر يا آئٽمز / گروپ جي ڪٽيل قيمت جي مذڪوره سيڪڙو (%) کان گهٽ نه هجي. لازمي پروڪيورنگ ايجنٽس کي پروڪيورمينٽ ڊائريڪٽريٽ سينٽرل ويئر هائوس، ڊاٽو يونيورسٽي آف هيلٿ سائنسز (اوجها ڪيمپس)، سپارڪو روڊ، ويجهو مين يونيورسٽي روڊ، گلزار هجري، اسڪيم نمبر 33، ڪراچي تي اِي واڪ جمع ڪرائڻ جي مقرر ڪيل وقت کان پهرين پهچي وڃي جيڪا ساڳئي ڏينهن منجهند 11:30 وڳي کولي ويندي.

S#	Category	Tender Reference Number	Amount of Bid Security
1.	Procurement of Papers, Stationary, General & IT Consumable, Printing Material, IT Hardware & Network Items. DDP Basis (Excluding GST) Single Stage - One Envelope Procedure under Rule 46(1) of SPP Rules 2010, on rate contract basis.	DUHS/DP/2026/343	Amount indicated against each item in Section V of Bidding Documents (2% of Estimated Cost)
2.	Procurement of Furniture/ Fixtures for Construction of Seminar Hall DDP Basis (Excluding GST) Single Stage - One Envelope Procedure under Rule 46(1) of SPP Rules 2010.	DUHS/DP/2026/344	Amount indicated against each group in Section V of Bidding Documents (2% of Estimated Cost)

نوٽ:

- اِي ٻڌڻگ جي حوالي سان ڪنهن به سوال يا معلومات لاءِ ڊائريڪٽر پروڪيورمينٽ آفيس سان فون نمبر **021-38771111 (Ext.4433)** تي رابطو ڪريو.
- حڪومت طرفان موڪل يا غير يقيني صورتحال سبب ٽينڊر/واڪ ان جي ورنڊو ڏينهن ساڳئي هنڌ ۽ وقت تي جمع ڪيا ويندا ۽ کوليا ويندا.
- خریدار ايس پي پي رولز 2010 (ترميم ٿيل) جي واسطيدار شقن تحت ڪنهن به يا سڄي واڪن کي رد ڪرڻ جو حق محفوظ رکي ٿو.
- ڪنهن به ڏکيائي جي صورت ۾، واڪ ڏيندڙ ڪم وارن ڏينهن دوران EPADS هيلپ لائن **051-111-137-237** تي رابطو ڪري سگهن ٿا.

ڊائريڪٽر پروڪيورمينٽ
ڊاٽو يونيورسٽي آف هيلٿ سائنسز، ڪراچي

www.duhs.edu.pk
Sindh e-Procurement, Karachi - 74200 Pakistan
96-021-3861863 Fax: 021-3923695